

Duplo DSF-2000 Sheet Feeder

Instruction Manual



Provided By

MyBinding.com®
When Image Matters.

SHEET FEEDER

DSF-2000

INSTRUCTION MANUAL

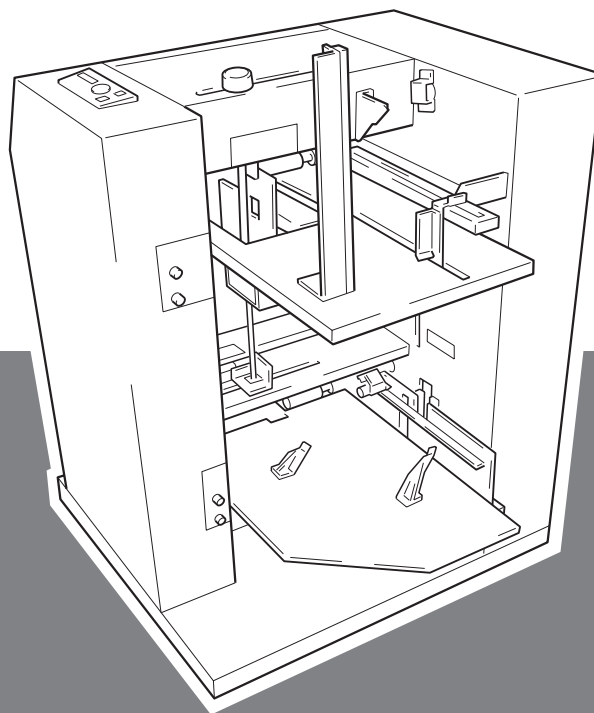

Duplo

MyBinding.com
When Image Matters.



DECLARATION OF CONFORMITY

DUPLO CORPORATION, located at 7-6, Izumi-honcho 1-chome, Komae-shi, Tokyo 201-8666, Japan, declares that the following product,

Name of product :

Sheet Feeder : Model DSF-2000 220–240 V 50/60 Hz

complies with the provisions defined in the regulations listed below.

Regulation : Low Voltage Directive 73 / 23 / EEC under IEC950 2nd (1991) + A1 (1992) + A2 (1993) + A3 (1995) + A4 (1996) including EN60950 2nd (1992) + A1 (1993) + A2 (1993) + A3 (1995) + A4 (1997) deviations.

Electromagnetic Compatibility Directive 89 / 336 / EEC under EN55011 (1998) + A1 (1999) Class B, EN55014-1 (1993) + A1 (1997) + A2 (1999), EN55014-2 (1997), EN61000-3-2 (1995) + A1/A2 (1998), EN61000-3-3 (1995)

ÜBEREINSTIMMUNGSERKLÄRUNG

Die DUPLO CORPORATION mit Sitz in 7-6, Izumi honcho 1-chome, Komae-shi, Tokyo 201-8666, Japan, versichert, daß das folgende produkt,

Bezeichnung des Produkts :

Bogen-Anleger : DSF-2000 220–240 V 50/60 Hz

Entspricht den Bestimmungen, wie sie durch die unten aufgeführten Vorschriften definiert sind.

Vorschriften : EWG – Niederspannungsrichtlinie 73 / 23 / EEC unter IEC950, 2. (1991) + A1 (1992) + A2 (1993) + A3 (1995) + A4 (1996) und EN60950, 2. (1992) + A1 (1993) + A2 (1993) + A3 (1995) + A4 (1997) Abweichungen.

Richtlinie für elektromagnetische Kompatibilität 89 / 336 / EEC unter EN55011 (1998) + A1 (1999) Klasse B, EN55014-1 (1993) + A1 (1997) + A2 (1999), EN55014-2 (1997), EN61000-3-2 (1995) + A1/A2 (1998), EN61000-3-3 (1995)

DECLARATION DE CONFORMITE

DUPLO CORPORATION, située à 7-6, Izumi honcho 1-chome, Komae-shi, Tokyo 201-8666, Japon, déclare que le produit Suivant ;

Nom du produit ;

Alimentation Feuille : DSF-2000 220–240 V 50/60 Hz

est conforme aux dispositions définies par les réglementations suivantes ;

Réglementations : Directive sur les basses tensions 73 / 23 EEC d'après IEC950-2 (1991) + A1 (1992) + A2 (1993) + A3 (1995) + A4 (1996) et EN60950-2 (1992) + A1 (1993) + A2 (1993) + A3 (1995) + A4 (1997) derogations.

Directive de compatibilité électromagnétique 89 / 336 / EEC d'après EN55011 (1998) + A1 (1999) CLASSE B, EN55014-1 (1993) + A1 (1997) + A2 (1999), EN55014-2 (1997), EN61000-3-2 (1995) + A1/A2 (1998), EN61000-3-3 (1995)

(Applicable to the 120 V machine)

This equipment has been tested and found to comply with the limits for a Class B digital device, pursuant to Part 15 of the FCC Rules. These limits are designed to provide reasonable protection against harmful interference in a residential installation. This equipment generates, uses and can radiate radio frequency energy and, if not installed and used in accordance with the instructions, may cause harmful interference to radio communications. However, there is no guarantee that interference will not occur in a particular installation. If this equipment does cause harmful interference to radio or television reception, which can be determined by turning the equipment off and on, the user is encouraged to try to correct the interference by one or more of the following measures:

- Reorient or relocate the receiving antenna.
- Increase the separation between the equipment and receiver.
- Connect the equipment into an outlet on a circuit different from that to which the receiver is connected.
- Consult the dealer or an experienced radio/TV technician for help.



INTRODUCTION

Thank you for purchasing this Duplo equipment. To ensure correct usage, please read this instruction manual thoroughly, especially the section Safety Precautions. After reading, please store this instruction manual in a safe place for future reference.



TABLE OF CONTENTS

| | | | |
|--|-----------|---|-----------|
| 1. Safety Precautions | 2 | 13. Other Settings | 35 |
| Warning and Caution Label Locations | 4 | 13-1. Setting the Buzzer On/Off | 35 |
| 2. Usage Precautions | 5 | 13-2. Setting the Shift Speed and Blink Speed of the LCD | 35 |
| 2-1. Power Supply | 5 | 13-3. Setting the Millimeters/Inches Display | 36 |
| 2-2. Operating Environment | 5 | 13-4. Changing the Set Speed/Paper Feed Speed (Changing the Processing Speed/Paper Feed Interval) | 37 |
| 2-3. Storage Conditions | 5 | 13-5. Setting the Double-feed Detection Sensor ... | 38 |
| 2-4. Maintenance | 5 | 13-6. Selecting the Separator Air Strength | 43 |
| 3. Names and Operation of Parts | 6 | 13-7. Setting the Driving Time of Suction Belt ... | 44 |
| 4. Control Panel | 10 | 13-8. Setting the Subtraction Processing and Addition Processing | 44 |
| 4-1. Names and Operation of Control Panel ... | 10 | 13-9. Setting of No. of Jogged Sheets | 45 |
| 4-2. Control Panel LCD and Selection Items on LCD | 11 | 14. Page Order and Direction of Paper on the Paper Feed Tray | 46 |
| 5. Check This before Use | 19 | 14-1. Paper Stacked on Paper Feed Tray A | 46 |
| 5-1. Turning ON the Power | 19 | 14-2. Paper Stacked on Paper Feed Tray B | 48 |
| 5-2. Up/Down Operations of Paper Feed Tray | 20 | 15. Stacking Paper on the Paper Feeder A and Adjusting Paper Feed | 49 |
| 6. Operations | 21 | 16. Stacking Paper on the Paper Feeder B and Adjusting Paper Feed | 51 |
| 7. Paper Feeder B (Cover Feeder) | 25 | 17. Auxiliary Stack Guide A | 52 |
| 7-1. Using the Paper Feeder B | 25 | 18. When Error Occurs | 53 |
| 8. End Mark Detection Function | 26 | 18-1. Correcting Paper Jamming | 53 |
| 8-1. Number/Set Check Function (Count) and Random Binding Function (Random) Using the End Mark | 26 | 18-2. When the Error Message "PAPER JAM" is Displayed at the LCD | 54 |
| 8-2. Setting the End Mark Detection Function ... | 27 | 18-3. When the Machine Stops Due to Errors ... | 55 |
| 8-3. Printing the End Mark | 29 | 18-4. When the Error Message "Finisher Error" is Displayed at the LCD | 56 |
| 9. Reversal Mechanism | 30 | 19. When the Error Message "Malfunction" is Displayed | 57 |
| 9-1. Selecting the Reversal Mechanism | 30 | 20. Cleaning | 58 |
| 10. Automatic Size Detection Function | 31 | 21. Troubleshooting | 59 |
| 10-1. Detectable Standard Size Paper | 31 | 22. Specifications | 60 |
| 10-2. Selecting the Automatic Size Detection Function | 31 | | |
| 11. Setting the Paper Size | 32 | | |
| 12. Custom Sizes | 34 | | |
| 12-1. Entering the Custom Size | 34 | | |







1. SAFETY PRECAUTIONS

Always observe the cautions and warnings given below to prevent personal injury or property damage.

■ The degree of danger and damage that could occur is indicated on two levels by the following marks.

-  **WARNING** : Ignoring this mark could result in the possibility of serious injury or even death.
-  **CAUTION** : Ignoring this mark could result in the possibility of injury or physical damage.

■ The following graphic symbols indicate the various types of action to be performed or avoided.

-  This graphic symbol indicates a forbidden action.
 -  means “Do not disassemble.”
 -  means “Do not touch.”
-  This graphic symbol indicates actions that must be performed.
 -  means “Disconnect the power plug.”
-  This graphic symbol indicates a “Caution” that must be observed.
 -  means “Caution: high temperature.”

WARNING:

 Do not place metal objects or vessels containing liquids on top of the unit. The entry of any metal object or liquid could result in fire or electrical shock.

 Do not insert any metal or easily-combustible object inside this unit. This could result in fire or electrical shock.

 Do not touch or insert foreign objects into any rotating part during operation. This could result in injury.

 Do not remove the cover or back panel. This unit contains high-voltage components that could cause electrical shock.

 Do not disassemble, modify or repair this unit. There is a danger of fire, electrical shock or injury. Contact your dealer when repairs are necessary.

 Use only the power supply voltage specified on the main nameplate. Using other voltages could result in fire or electrical shock.

 Keep this unit and the power cord away from heaters and heater vents. Excessive heat could melt the cover or power cord covering, and result in fire or electrical shock.



Do not use flammable sprays inside or near the unit (e.g. when cleaning the unit). Such flammable gas may ignite and cause a fire or combustion.



Make sure that the combined power consumption of the appliances to be connected does not exceed the capacity rating of the power outlets or plug receptacles. Exceeding the capacity rating could cause the power outlets, plug receptacles, or power extension cords to overheat and catch fire.



Remove any dust that accumulates on the power plug prongs and the surface of the plug from which the prongs extend. Accumulated dust can result in fire.



If any foreign object such as metal or liquid should enter this unit, immediately turn the unit off at the power switch and disconnect the power plug from the power outlet. Failure to do so could result in fire or electrical shock. Contact your dealer immediately.



Do not damage the power cord or power plug. (Do not scratch, alter, bend, twist, pull or place heavy objects on the power cord or power plug.) This could result in damage, fire or electrical shock.



Always grip the plug when disconnecting the power plug from the power outlet. Pulling on the power cord could cause damage, resulting in fire or electrical shock.



Do not handle the power plug with wet hands. This could result in electrical shock.



Before cleaning this unit, turn the unit off at the power switch and disconnect the power plug from the power outlet. Accidental operation of the unit during cleaning could result in injury.

CAUTION:



Always disconnect the power plug from the power outlet when the unit is not to be used for an extended period. Failure to do so could result in fire due to leakage current if the insulation should deteriorate.



Install this unit on a level, stable stand or floor, with sufficient space around it. Failure to do so could result in the unit overturning and causing injury.



Do not install this unit in a location where there is excessive humidity or where contact with water is possible. Poor choice of location could result in deterioration of the insulation, fire or electrical shock.



Disconnect the power plug from the power outlet before attempting to move this unit. Failure to do so could result in power cord damage, fire or electrical shock.

SAFETY PRECAUTIONS (continued)

Warning and Caution Label Locations

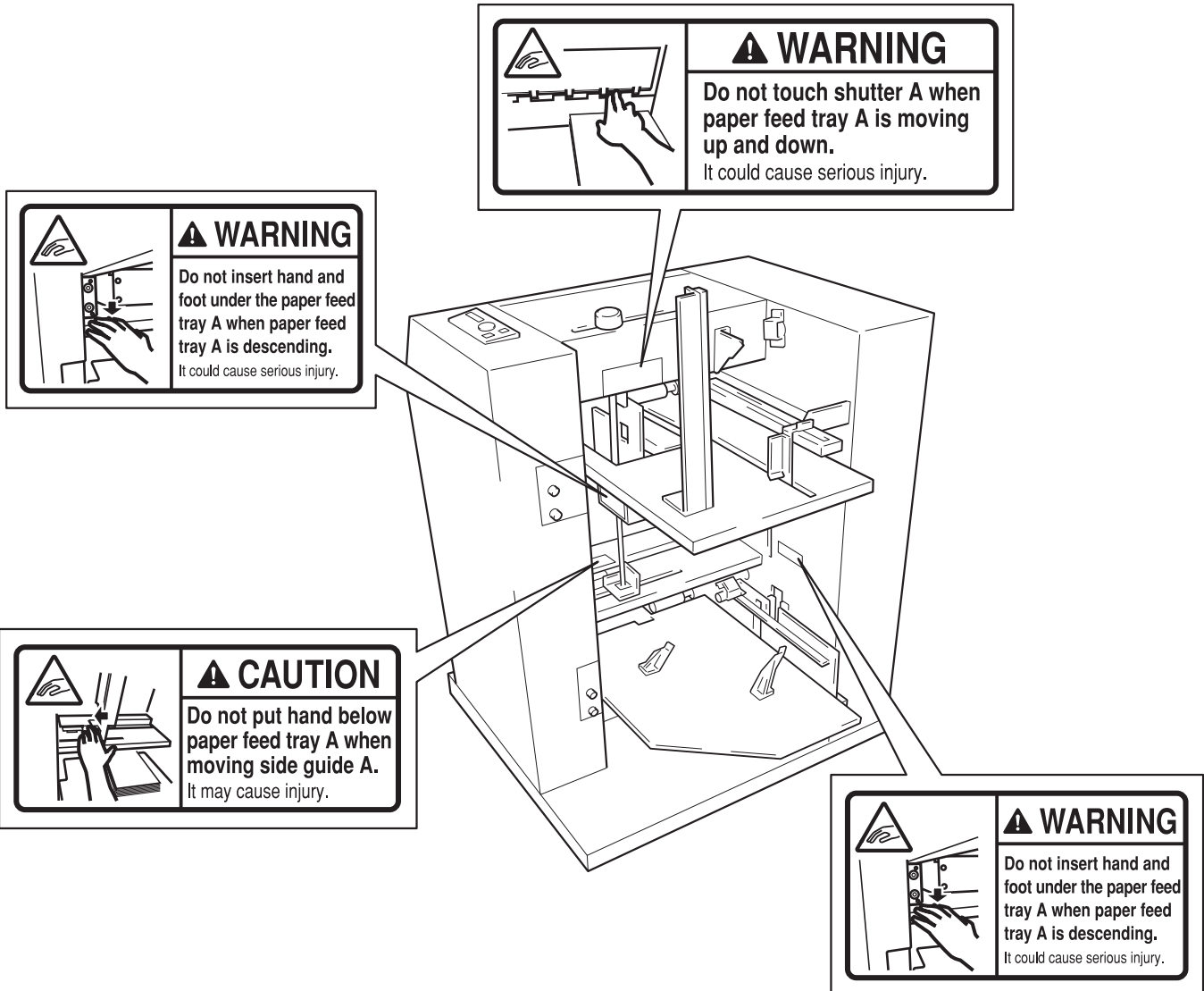

2. USAGE PRECAUTIONS

2-1. Power Supply

- This equipment shall be installed near the socket-outlet where the plug on the power supply cord is easily accessible.
- Make sure the power supply used is always within the following range.
 - 220 to 240 V AC, 50/60 Hz (120 V AC, 60 Hz)
- When you power other appliances from the same AC outlet, make sure that the combined power consumption does not exceed the power supply capacity.
 - Rated power of this equipment: 0.9 A (220 to 240 V AC)/1.8 A (120 V AC)

2-2. Operating Environment

Operate this unit in the following environment:

- where the temperature range is between 5 and 35°C,
- where the humidity range is between 20 and 85% RH (no dew condensation),
- which is not subject to direct sunlight,
- which is subject to little or no vibration,
- where there are no harmful chemicals,
- which is reasonably free from dust,
- which is free from air-borne salt, and
- where the equipment will not be exposed to water.

2-3. Storage Conditions

Store this unit in the following environment:

- where the temperature range is between –5 and +50°C,
- where the humidity range is between 10 and 90% RH (no dew condensation),
- which is not subject to direct sunlight,
- which is subject to little or no vibration,
- where there are no harmful chemicals,
- which is reasonably free from dust,
- which is free from air-borne salt, and
- where the equipment will not be exposed to water.

2-4. Maintenance

To protect the special features of this unit, the customer should never apply oil or grease to the parts (except when the customer is specifically requested to do so in this instruction manual). Please contact your dealer in case of any problem.

3. NAMES AND OPERATION OF PARTS

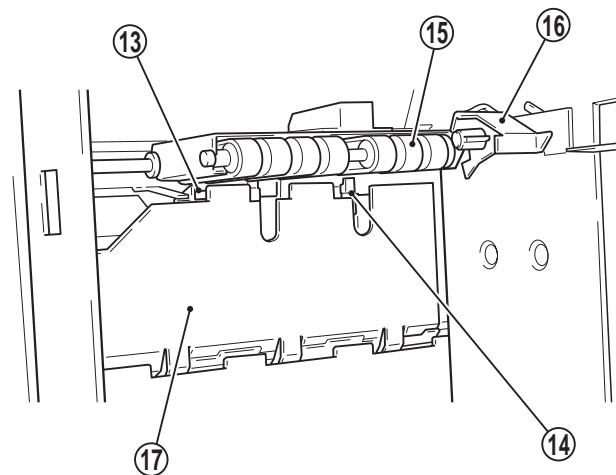
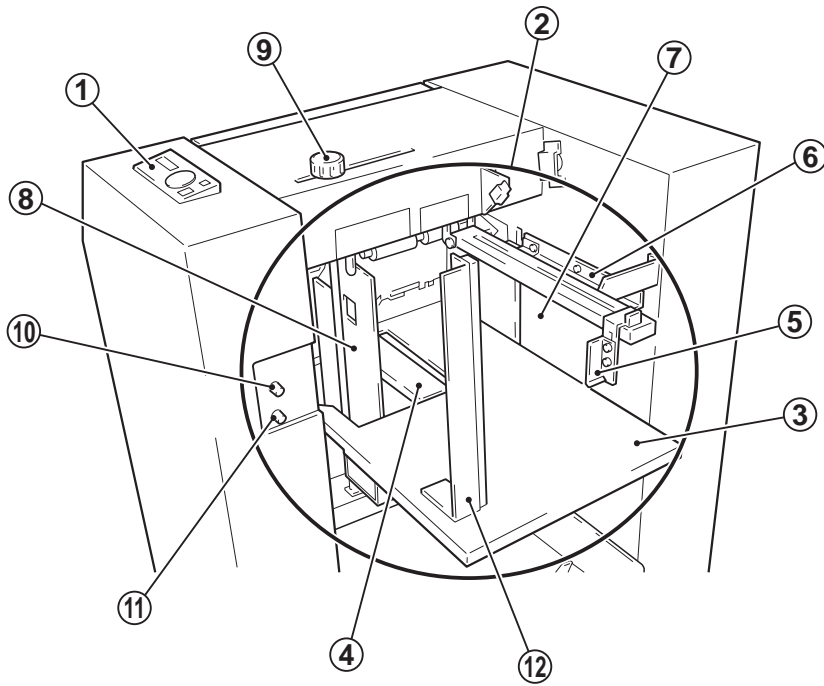

3. NAMES AND OPERATION OF PARTS

| No. | Name | Operation |
|-----|---------------------------------|---|
| ① | Control panel | For details, refer to “4. CONTROL PANEL”. |
| ② | Paper feeder A | Paper feeder normally used. |
| ③ | Paper feed tray A | Stacks the paper to be bound. |
| ④ | Auxiliary paper feed plate A | Prevents entangling of paper at the entrance of the paper feed tray A. Remove when using paper less than 200 mm (7.87") wide. |
| ⑤ | Rear guide A | Align to the rear edge of the paper stacked on the paper feed tray A to prevent the deviation of paper by the separator air. |
| ⑥ | Sub guide A | Holds the edge of conveyed paper to prevent deviation of paper. |
| ⑦ | Reference guide A | Press paper against this when stacking. |
| ⑧ | Side guide A | Align to the left edge of the paper stacked on the paper feed tray A. |
| ⑨ | Side guide moving dial A | Turn to adjust the position of the side guide A. |
| ⑩ | Separator air adjustment knob A | Knob for adjusting the position of the shutter A to adjust the amount of separator air blown out. |
| ⑪ | Separator adjustment knob A | Knob for adjusting the position of the separator A. |
| ⑫ | Auxiliary stack guide A | Refer to “17. AUXILIARY STACK GUIDE A”. |
| ⑬ | Separator air duct A | Blows out air to separate paper stacked on the paper feed tray A. |
| ⑭ | Separator A | Prevents double-feeding at the paper feeder A. |
| ⑮ | Suction belt A | Sucks and conveys paper. |
| ⑯ | Level sensor A | Sensor which determines the position of the paper raised by the separator air. Adjusted using a knob. |
| ⑰ | Shutter A | For adjusting the amount of air blown out to separate paper by covering the separator air duct A. |

3. NAMES AND OPERATION OF PARTS

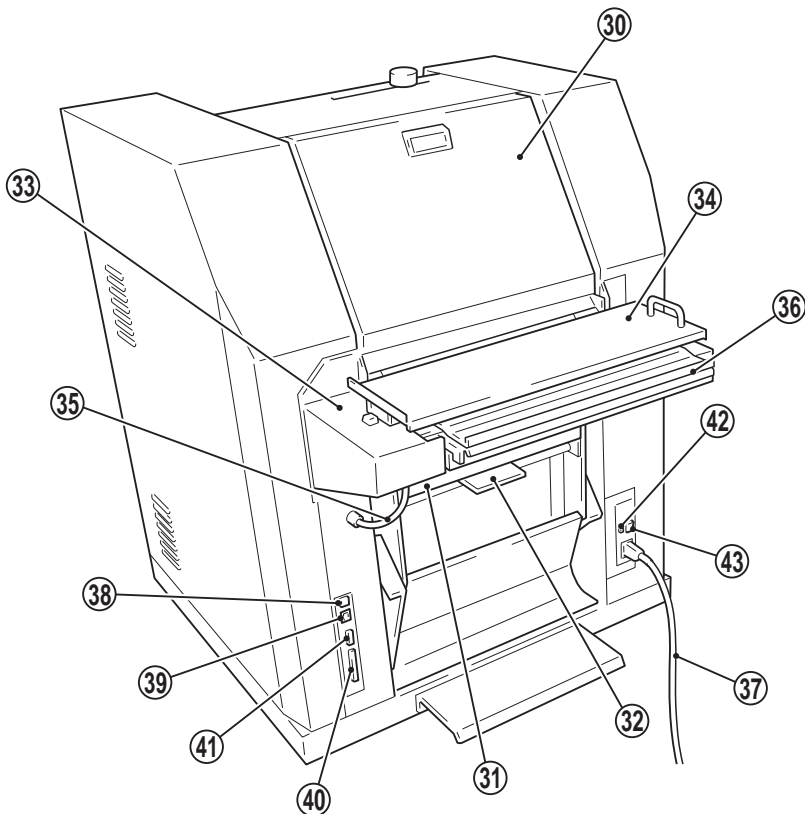
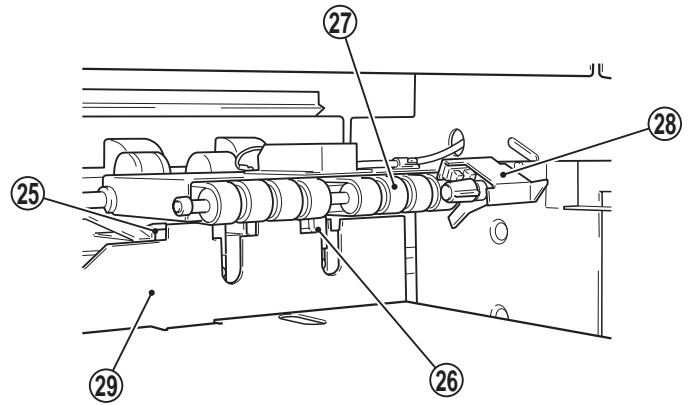
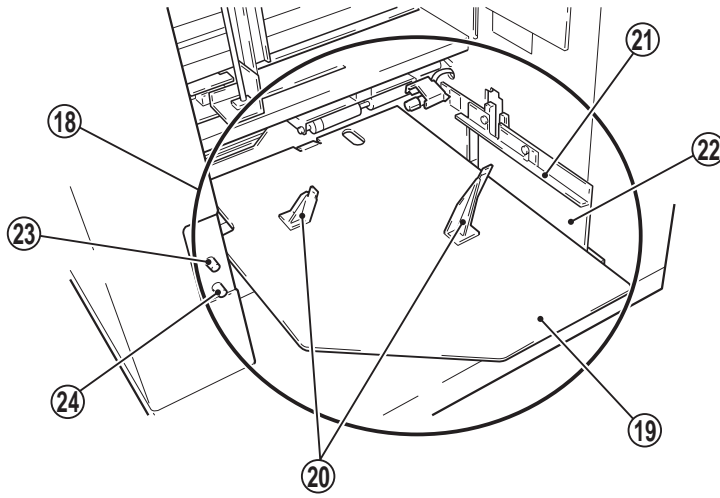

3. NAMES AND OPERATION OF PARTS

| No. | Name | Operation |
|-----|---------------------------------|---|
| ⑱ | Paper feeder B | Used to insert cover paper. |
| ⑲ | Paper feed tray B | Stacks cover paper. |
| ⑳ | Stack guide B | Holds the edge of cover paper stacked on the paper feed tray B, and maintains the position. |
| ㉑ | Sub guide B | Holds the edge of conveyed cover paper to prevent deviation of cover paper. |
| ㉒ | Reference guide B | Press cover paper against this when stacking. |
| ㉓ | Separator air adjustment knob B | Knob for adjusting the position of the shutter B to adjust the amount of separator air blown out. |
| ㉔ | Separator adjustment knob B | Knob for adjusting the position of the separator B. |
| ㉕ | Separator air duct B | Blows out air to separate cover paper stacked on the paper feed tray B. |
| ㉖ | Separator B | Prevents double-feeding at the paper feeder B. |
| ㉗ | Suction belt B | Sucks and conveys cover paper. |
| ㉘ | Level sensor B | Sensor which determines the position of the cover paper raised by the separator air. Adjusted using a knob. |
| ㉙ | Shutter B | For adjusting the amount of air blown out to separate paper by covering the separator air duct B. |
| ㉚ | Upper door | Open when correcting jams. |
| ㉛ | Lower door | Open when correcting jams. |
| ㉜ | Lower door release lever | Pull up to open the lower door. |
| ㉝ | Bridge | Feeds paper to the downstream processing unit. |
| ㉞ | Bridge door | Open when paper jams at the bridge. |
| ㉟ | Bridge cable | Connect to this unit. |
| ㊱ | Ejection guide | Finely adjusts the paper ejection height by changing the angle. |
| ㊲ | Power cord | Connect to an outlet. |
| ㊳ | D-PORT 1 connector | Normally not used. |
| ㊴ | D-PORT 2 connector | Connector for connecting the connecting cable from a downstream processing unit such as the DBM-120 Sheet by Sheet. |
| ㊵ | Connector 1 | Connector for connecting the connecting cable from a downstream processing unit such as the DBM-400 Sheet by Sheet. |
| ㊶ | Connector 2 | Connector for optional devices. Normally not used. |
| ㊷ | Remote switch | Refer to “5-1. Turning ON the Power”. |
| ㊸ | Main power switch | Refer to “5-1. Turning ON the Power”. |

4. CONTROL PANEL

4-1. Names and Operation of Control Panel

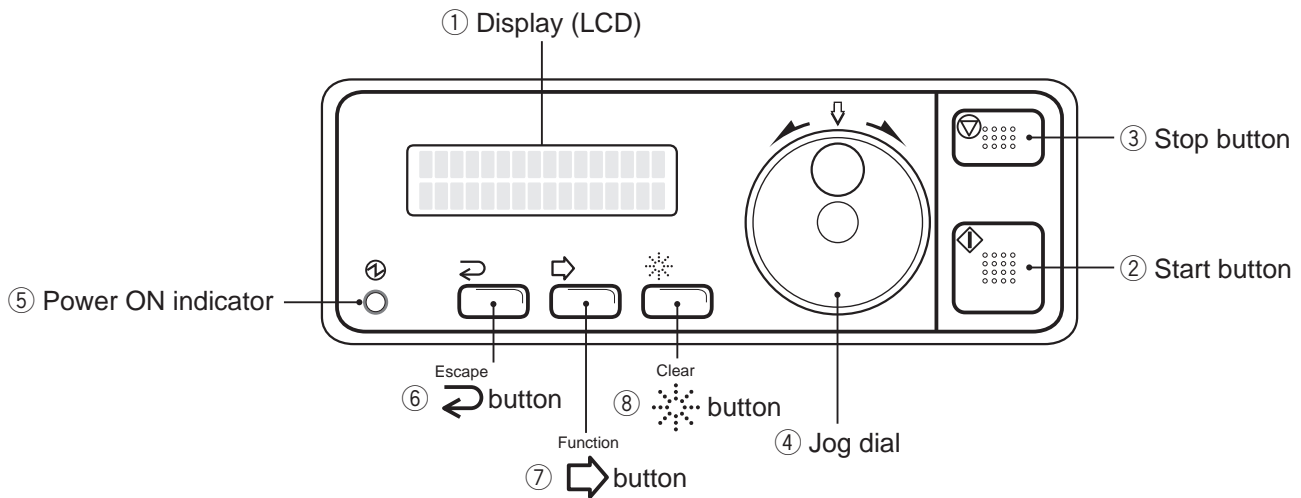

| No. | Name | Operation |
|-----|--------------------|---|
| ① | Display (LCD) | Displays items, settings, and messages. |
| ② | Start button | Press to operate the machine. |
| ③ | Stop button | Press to stop the machine. |
| ④ | Jog dial | Turn to display the mode or value to be changed, and press to confirm the changed mode or value. |
| ⑤ | Power ON indicator | Lights up in green when power is turned on. |
| ⑥ | Escape button | Press to return to the previous item. |
| ⑦ | Function button | Use to operate only the conveyor (Forced ejection). When entering numbers, turning the jog dial while pressing this button changes the number in units of 100. |
| ⑧ | Clear button | Press once at the initial screen to clear the number of processed sets to "0". The remaining number of sets display shows the value previously set. Press at the numerical input screen to clear the setting to "0" or set the minimum value which can be set. |

* When the machine is operating or the paper feed tray is moving up and down, all buttons will be ineffective. (Only the stop button will be effective while the machine is operating.)

4-2. Control Panel LCD and Selection Items on LCD

The jog dial on the control panel is used to change and confirm items and values in this machine. Turning the jog dial switches the item displayed on the LCD in order, and pressing it confirms the mode or value changed to.

(1) Example of initial screen of LCD

| | | | | | | | | | | | | | | | |
|---|---|---|---|---|---|---|---|---|---|---|---|---|---|---|---|
| A | 3 | | | | | C | o | v | | | A | S | Z | | * |
| 5 | 5 | 5 | 5 | / | 7 | 7 | 7 | 7 | (| 1 | 0 |) | | M | C |

“A3” : Paper size

“Cov” : Indicates that the paper feeder B (cover paper) is used
 (“NCov” is displayed when not used)

“ASZ”^{*1} : Indicates that the automatic size detection is on
 (“MSZ” (manual size) is displayed when this function is not used)

“*” : Indicates that the reversal mechanism is on
 (Nothing is displayed when this mechanism is not used)

“5555”^{*2} : Number of sets processed or remaining number of sets

“7777” : Number of sets set

“(10)” : Number of sheets which can be fed from paper feeder A in one set
 (Does not include the cover fed from paper feeder B)

“MC” : Indicates that the end mark sensor (number of sheets check function) is on
 “MR” is displayed when the random binding function is selected
 (Nothing is displayed when this function is not used)

*1: When the DBM-400 Sheet by Sheet is connected, the automatic size detection function cannot be used. (“MSZ” is always displayed)

*2: Take note that this value may not always match the value of “TC” (total count) displayed on the DBM-400T when the DBM-400T is connected.

4. CONTROL PANEL

(2) LCD map

The LCD map displays the hierarchy of the LCD in an easy to understand format.

- Turning the jog dial switches the display within the same hierarchy, and press to move to the hierarchy below (right side of the LCD map).
- If no hierarchy exists below, turning the jog dial selects an item or sets a value. Pressing it confirms the selected item or value set.
- The * mark indicates that items can be selected and values set by turning the jog dial.
- Pressing the ↶ (Escape) button returns to the hierarchy above (left side of the LCD map). Pressing for the number of hierarchies moved down from the initial screen returns to the initial screen. (Pressing the start button to start the machine also returns to the initial screen.)
- The items marked ♦ cannot be set (used) when the DBM-400 Sheet by Sheet is connected.

Selecting (Setting) item

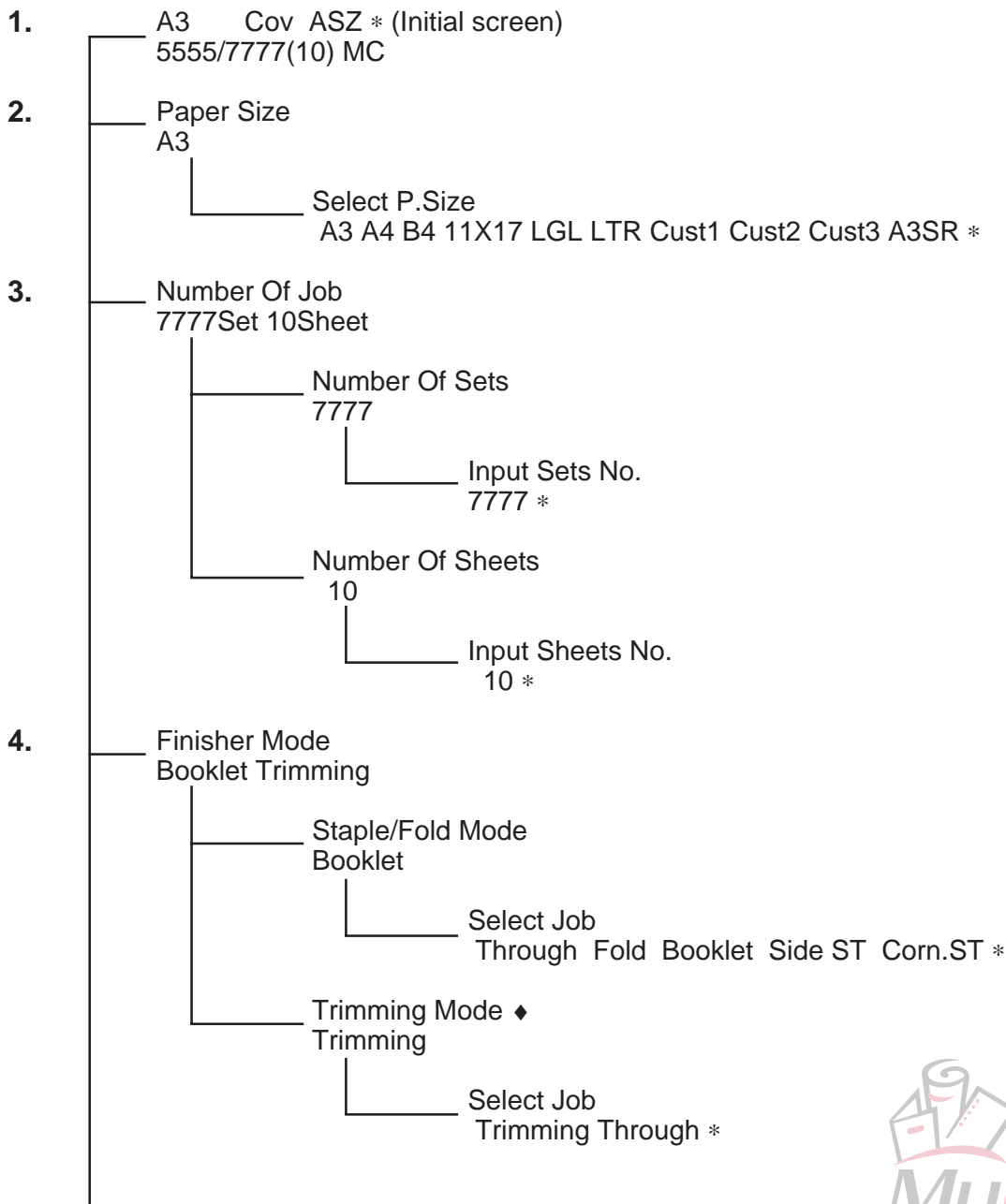

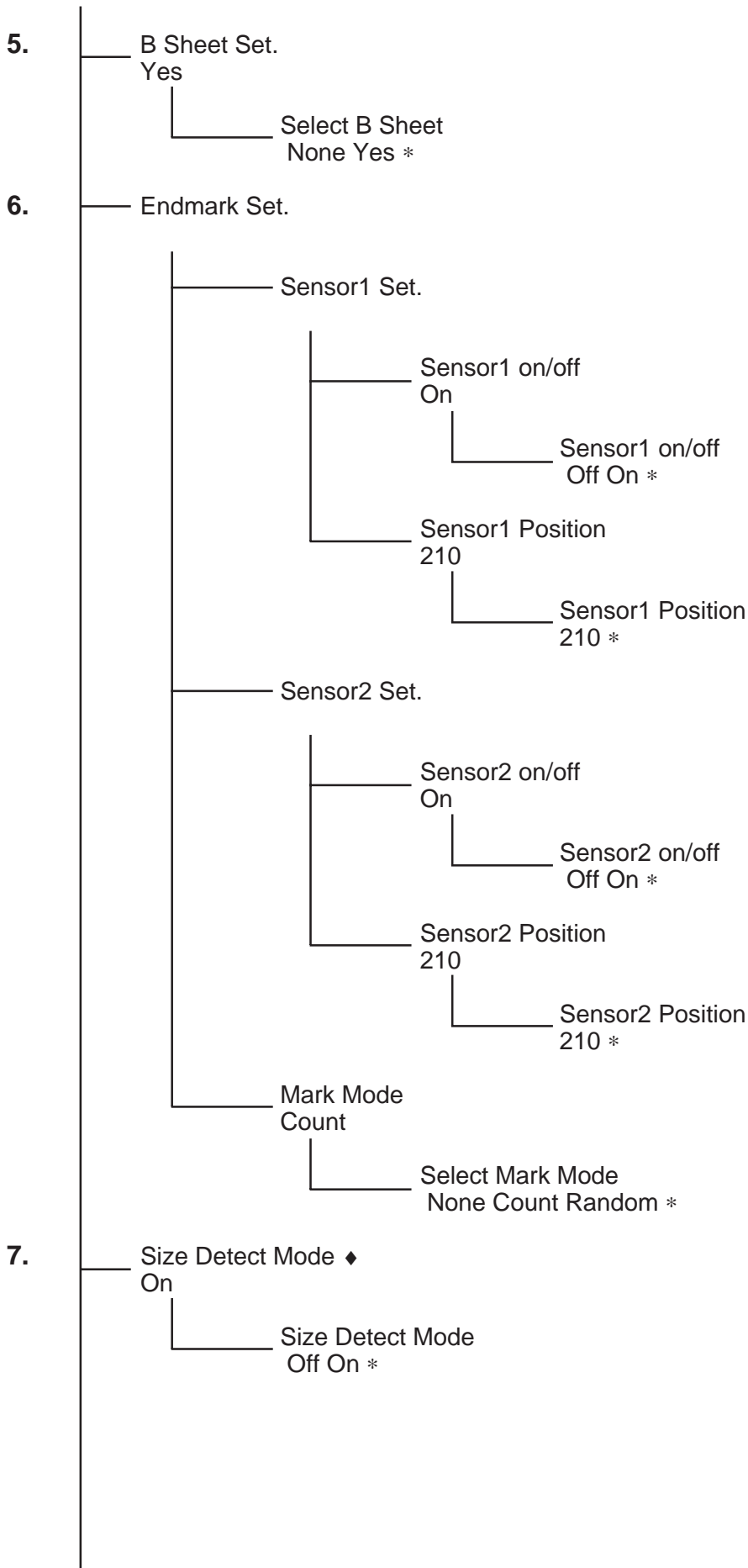

4. CONTROL PANEL

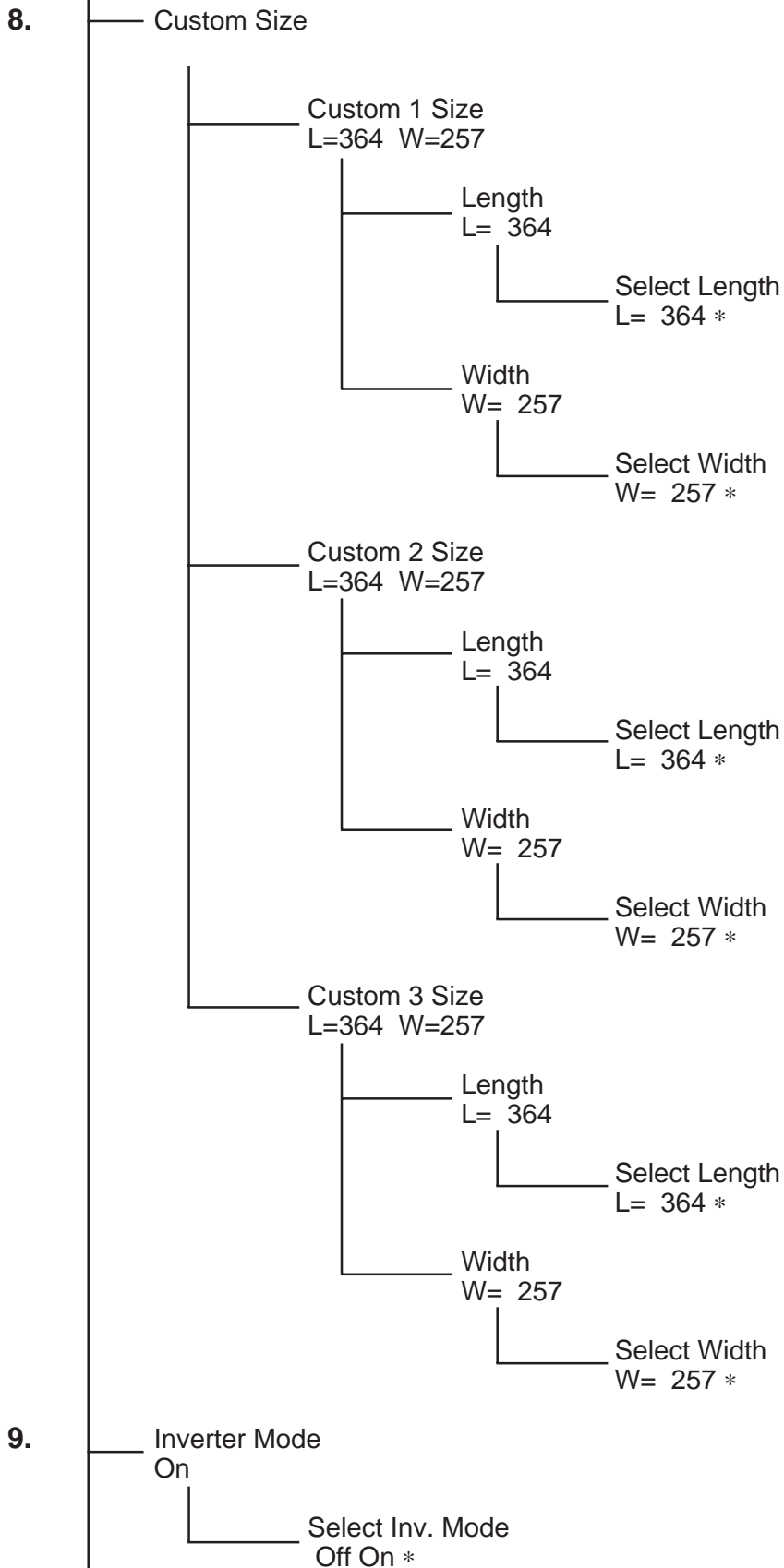

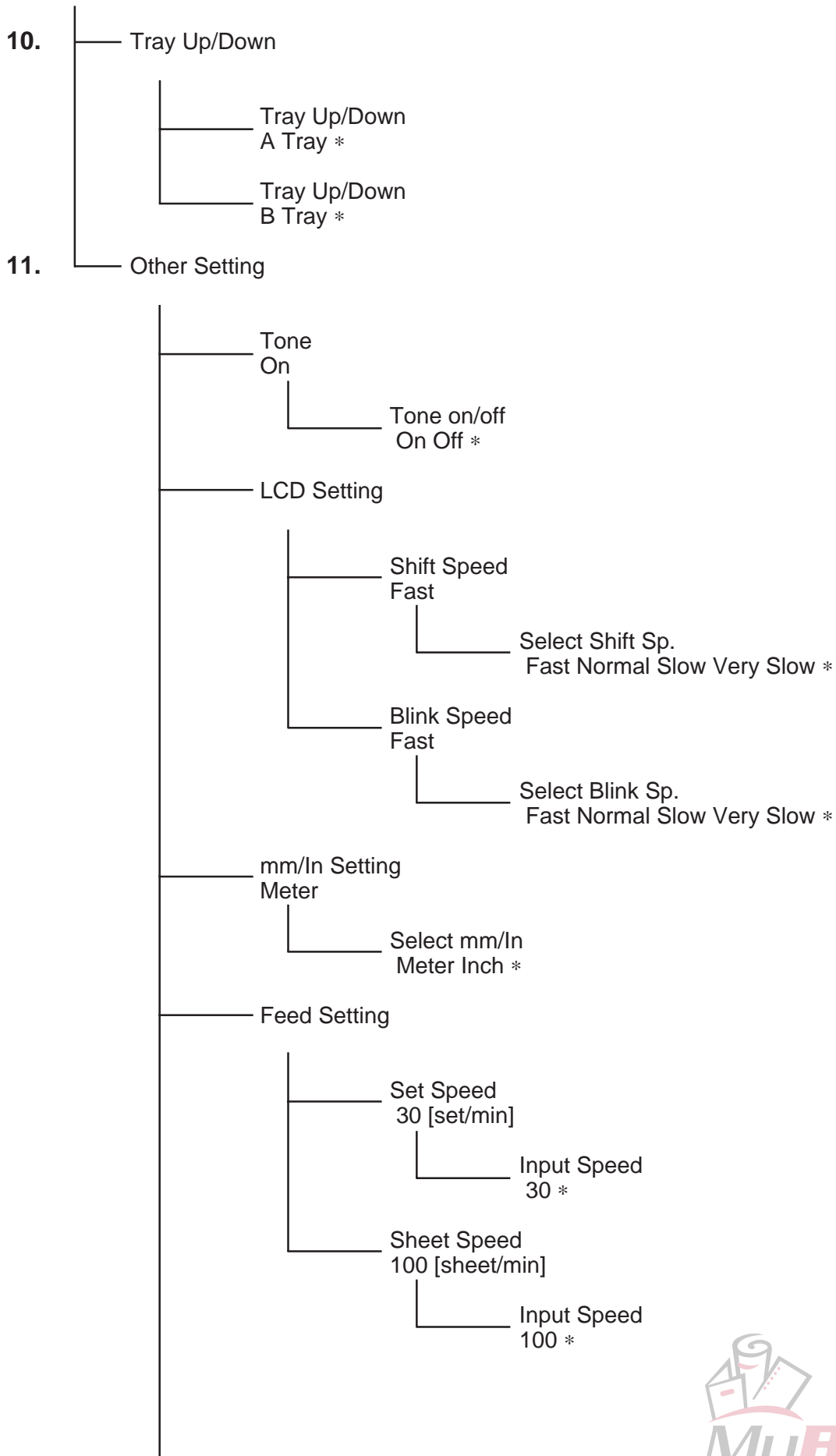

4. CONTROL PANEL

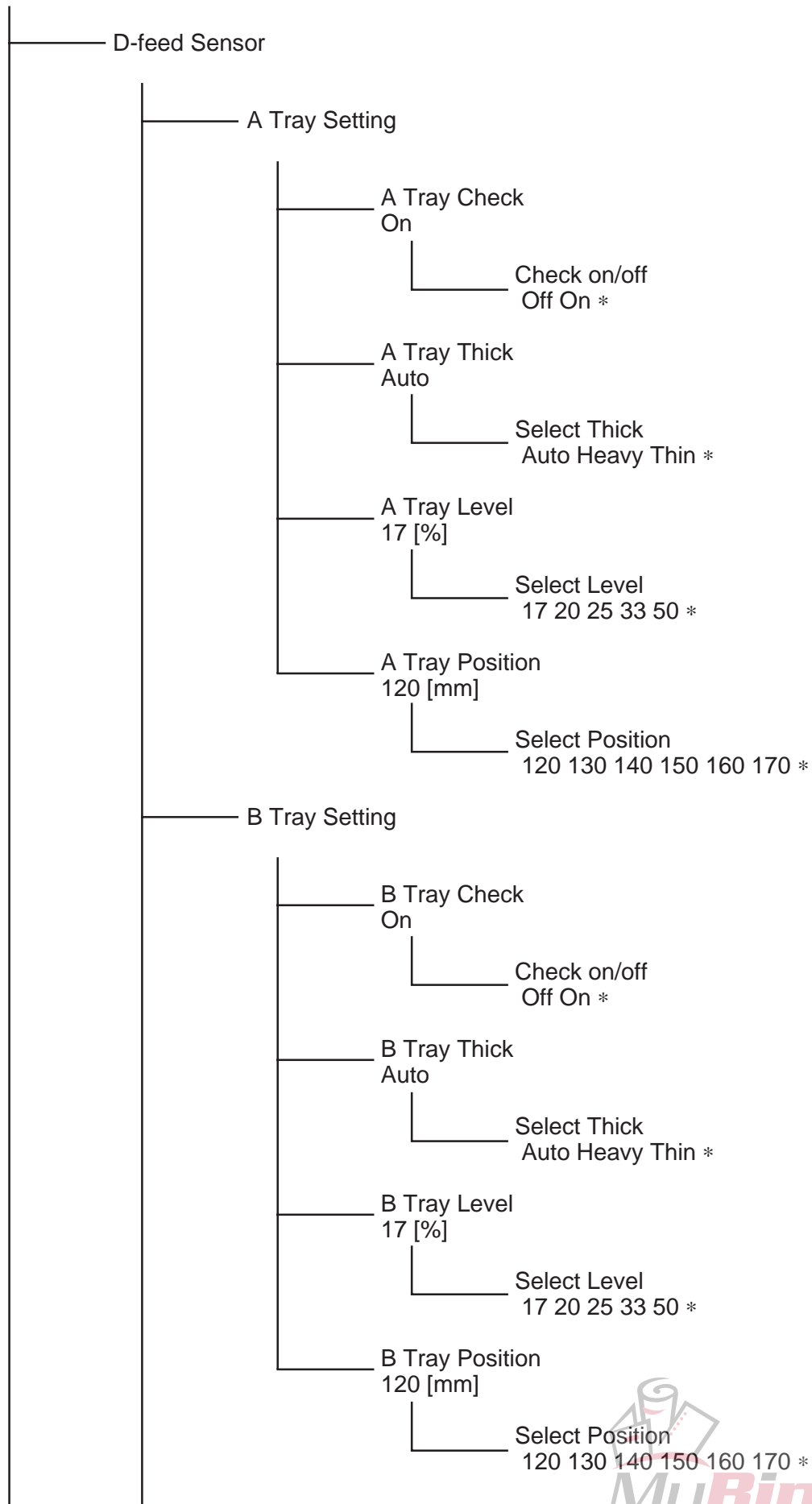

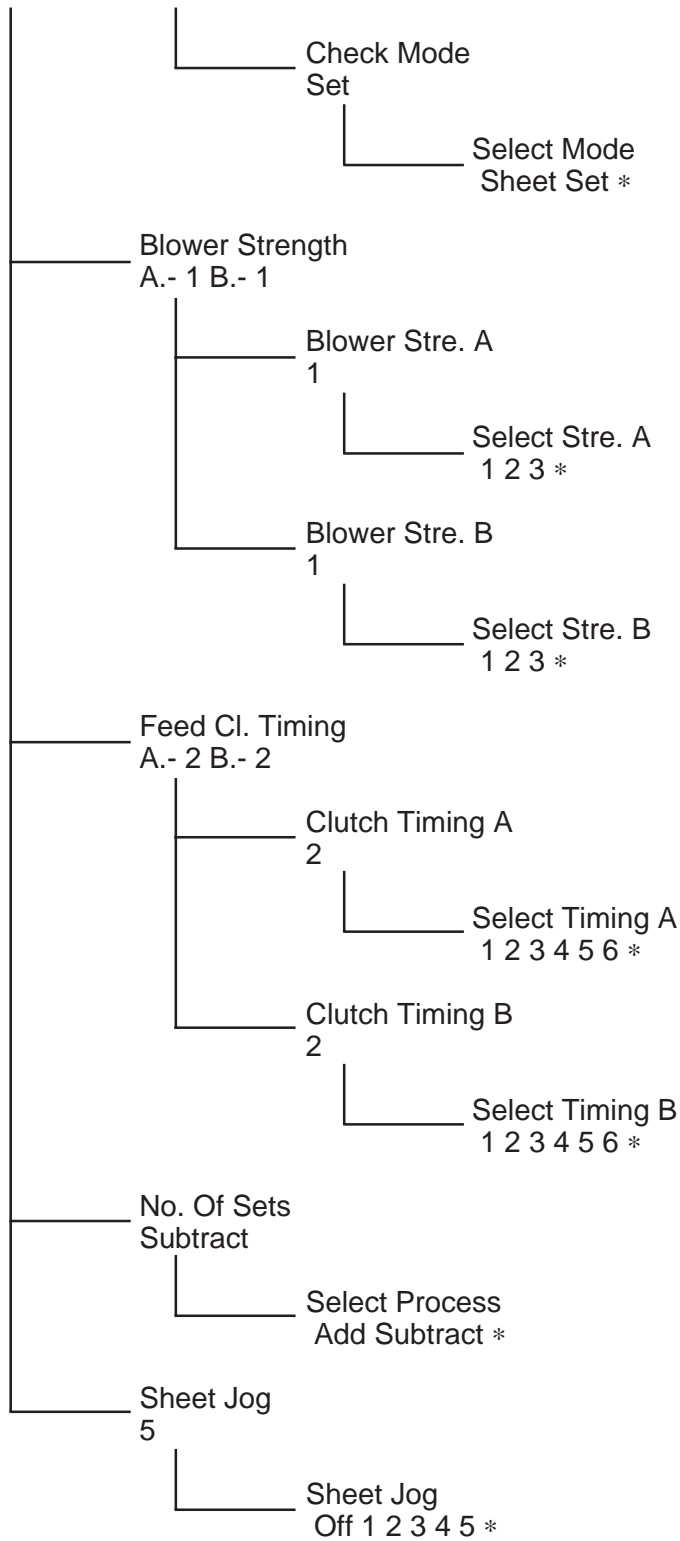

4. CONTROL PANEL

(3) Error messages

Displays error messages on the LCD when errors occur.

- “Sheet Feeder Initializing.” : Displayed at power ON and during initialization when the door is closed.
- “PAPER JAM” : Displayed when paper jam occurs. Displays the area of the jam at the bottom.
- “Door open” : Displayed when a door is open. Displays the opened door at the bottom. (“Upper”, “Lower”, or “Bridge”)
- “Paper empty” : Displayed when there is no paper on the paper feed tray. Displays the empty tray at the bottom. (“A Tray” or “B Tray”)
- “Feed miss” : Displayed when mis-feeding occurs. Displays the tray where mis-feeding has occurred at the bottom. (“A Tray” or “B Tray”)
- “EndMark Error” : Displayed when detection error related to the end mark occurs. Displays the error details at the bottom.
- “Double feed” : Displayed when double-feeding occurs. Displays the tray where double-feeding has occurred at the bottom. (“A Tray” or “B Tray”)
- “Finisher Error” : Displayed when error occurs in the downstream processing unit.

(4) Trouble message

“Malfunction” is displayed when problems of the machine occur.

5. CHECK THIS BEFORE USE

5-1. Turning ON the Power

◆ When connecting the DBM-120 Sheet by Sheet

Turn ON the main power switch of the DBM-120 Sheet by Sheet and power switch of the DBM-120T, and press the ON side “I” of the main power switch of this unit.

(Set the power switch of the DBM-120 Sheet by Sheet to OFF, push down the maintenance switch of the DBM-120T, and set the remote switch of this unit to the side (upper side).)

NOTE : If DBM-120 Sheet by Sheet and DBM-120T are connected to this unit, the remote function operates and all units connected will turn ON about the same time when this unit is turned ON. However, when this unit is turned OFF, power will be turned OFF from this unit in order, meaning the units connected will go OFF with a delay of several seconds in between.

◆ When connecting the DBM-400 Sheet by Sheet

Press the ON side “I” of the main power switch of this unit, and then turn ON the power switches of the downstream processing units connected one by one. Turn ON the DBM-400 Sheet by Sheet last.

When turning OFF the power switches, turn OFF this unit the last.

NOTE : If this order in which the power switches are turned ON and OFF is not followed, the downstream processing units may not operate correctly.

Main power switch

Switch which supplies power to this unit. At power ON, this unit will carry out initialization.

If the downstream processing unit has a remote function, this switch can be also used to turn ON and OFF the downstream processing unit.

Remote switch

Switch which turns on the main power switch of this unit. Normally set to the side (upper side).

Remote function

This function is used for turning ON/OFF the power of each unit using just one power switch when linking several processing units.

NOTE : When the DBM-400 Sheet by Sheet is connected, this function cannot be used.

Initialization

Initialization is the process in which the conveyor operates and ejects paper remaining in the machine, and at the same time detection of paper jamming is carried out. If the paper feed trays are not at the lowermost position, and no paper is stacked, they will move down to the lowermost position.

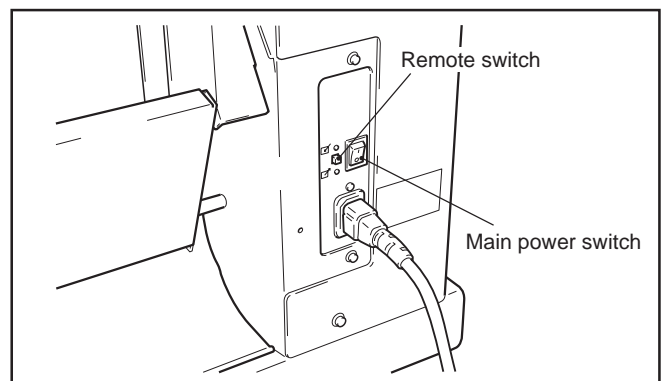

5-2. Up/Down Operations of Paper Feed Tray

- 1 Turn the jog dial at the initial screen and display “Tray Up/Down”, and press the jog dial to confirm the setting.

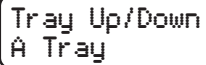

Tray Up/Down
A Tray

- 2 To move the paper feed tray of the paper feeder A up and down, turn the jog dial and display “A Tray” at the bottom. To move the paper feed tray of the paper feeder B up and down, display “B Tray”. Press the start button to raise the tray and the stop button to lower the tray. The tray will be moving while these buttons are pressed.

NOTE : The tray will not rise if there is no paper on the tray.

6. OPERATIONS

1 Stack paper and perform the various adjustments of the paper feed section. Refer to “**15. STACKING PAPER ON THE PAPER FEEDER A AND ADJUSTING PAPER FEED**” and “**16. STACKING PAPER ON THE PAPER FEEDER B AND ADJUSTING PAPER FEED**”.

2 Perform the various settings according to the required operation on the control panel.

(1) Set the paper size

Refer to “**11. SETTING THE PAPER SIZE**”.

NOTE : This setting is not required if using the automatic size detection function when connecting the DBM-120 Sheet by Sheet. Refer to “**10. AUTOMATIC SIZE DETECTION FUNCTION**”.
When the DBM-400 Sheet by Sheet is connected, the automatic size detection function cannot be used.

(2) Setting the downstream processing unit mode

When connecting the DBM-120 Sheet by Sheet

① Turn the jog dial at the initial screen to display the “Finisher Mode”, and press the jog dial to confirm the setting.

Staple/Fold Mode
Booklet

② Turn the jog dial and display “Staple/Fold Mode” to set the DBM-120 Sheet by Sheet or display “Trimming Mode” to set the DBM-120T, and press the jog dial to confirm the setting.

● Set the “Staple/Fold Mode” as follows on the left edge, and press the jog dial to confirm.

To eject paper without processing : “Through”
To perform folding : “Fold”
To perform saddle-stapling and folding : “Booklet”
To perform side-stapling : “Side ST”
To perform corner-stapling : “Corn.ST”

Select Job
Through Fold Bo

● Set the “Trimming Mode” as follows on the left edge, and press the jog dial to confirm.

To perform trimming : “Trimming”
To not perform trimming : “Through”

Select Job
Trimming Throug

NOTE : ● This setting will not change even if the power is turned off and turned on again.
● Adjust the downstream processing unit at the downstream processing unit side.

When connecting the DBM-400 Sheet by Sheet

- ① Turn the jog dial at the initial screen to display the “Finisher Mode”, and press the jog dial to confirm the setting.

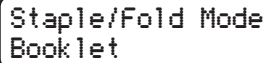

Staple/Fold Mode
Booklet

- ② Turn the jog dial to display “Staple/Fold Mode”, and press the jog dial to confirm the setting.
“Trimming Mode” cannot be set.

Set the “Staple/Fold Mode” as follows on the left edge, and press the jog dial to confirm.

- | | |
|--|--|
| To perform folding | : “Fold” |
| To perform saddle-stapling and folding | : “Booklet” |
| To perform side-stapling | : “Side ST” (Valid only when the paper size is set to “Custom Size”) |
| To perform corner-stapling | : “Corn.ST” (Valid only when the paper size is set to “Custom Size”) |

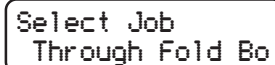

Select Job
Through Fold Bo

- NOTE** : ● “Through” cannot be set. And “Side ST” and “Corn.ST” cannot be set if the DBM-400T is connected.
● This setting will not change even if the power is turned off and turned on again.
● Adjust the downstream processing unit at the downstream processing unit side.

(3) Selecting and setting the paper feeder B

Refer to “7-1. Using the Paper Feeder B”.

- NOTE** : This setting will not change even if the power is turned off and turned on again.

3 To use the end mark detection function, set the end mark detection function. Refer to “8-2. Setting the End Mark Detection Function”.

4 To use the reversal mechanism, select the reversal mechanism. Refer to “9-1. Selecting the Reversal Mechanism”.

5 Enter the number of sets to be processed and the number of sheets in one set.

NOTE : The cover page fed from the paper feeder B is not included in the number of sheets of the set.

- ① Turn the jog dial at the initial screen to display “Number Of Job”, and press the jog dial to confirm the setting.
- ② Turn the jog dial and display “Number Of Sets” to enter the number of sets or display “Number Of Sheets” to enter the number of sheets in one set, and press the jog dial to confirm the setting.

<When entering the number of sets>

Input Sets No.
7777

<When entering the number of sheets in one set>

Input Sheets No.
10

- ③ Turn the jog dial and display the desired value, and press the jog dial to confirm the setting. The number of sets can be set between 1 and 9999. When the DBM-120 Sheet by Sheet is connected, the number of sheets in one set can be set between 1 and 99 in the “Through” mode and 1 and 20 sheets in other modes (1 to 19 when using paper feed tray B). When the DBM-400 Sheet by Sheet is connected, the number of sheets in one set including the cover when paper feed tray B is used can be set between 1 and 25 in the “Fold” mode and “Booklet” mode, and between 1 and 30 in the “Side ST” mode and “Corn.ST” mode.

If the number of sheets in one set or the setting of the downstream processing unit differs from the previous process, enter “1” for the number of sets, check the set processed by the downstream processing unit, and then process the remaining sets required.

NOTE : ● When using the random binding function of the end mark, there is not need to set the number of sheets for one set.
● The number (thickness) of sheets in one set is restricted by the downstream processing unit. Refer to the instruction manual on the downstream processing unit.

6. OPERATIONS

6 Perform test feeding. This memorizes the features of the paper set in the machine. As this step is required for double-feed detection, automatic size detection, and end mark detection, be sure to perform this step.

- ① Continue pressing the start button **for more than two seconds**, and release.
(Pressing the start button generates one short beep and another beep two seconds later. Release the button when the second beep sounds.)
* The beep will not sound if the buzzer ON/OFF setting is set to “Off”.
- ② When the double-feed detection function is set to “Set”, paper will be fed for the number of sets set. If set to “Sheet”, only the first sheet of each paper feeder will be fed.
- ③ When using the end mark detection function and the double-feed detection function is set to “Sheet”, perform test feeding after placing the paper printed with an end mark on the very top of paper feed tray A.
(Refer to “8-3. Printing the End Mark”.)
- ④ Check that the test-fed paper has been processed normally. If errors are found, correct the case, and test-feed again.
(Causes of the error include double-feed, different order of paper stacked, wrong number of sheets in set was entered, etc.)
Return the paper ejected in test feeding to each paper feed tray in the same direction and order as when they were stacked previously, or use the manual feed function of the downstream processing unit.

NOTE : ● If the paper used differs from the type used the last time (paper quality, thickness, size, color, or printing state), be sure to carry out test feeding each time.
● If the DBM-120 Sheet by Sheet is connected, the test-fed paper will be ejected without being processed.
● If the DBM-400 Sheet by Sheet is connected, the test-fed paper will be ejected with being processed.

7 Press the start button to start the process. Take note that pressing the start button for more than 2 seconds starts test feeding. After processing the number of sets set, the machine will stop.

To stop the machine halfway through, press the stop button. Pressing the stop button once stops the machine after the set currently being processed has ended. Pressing the stop button twice stops the machine even if a set is current being processed.

NOTE : ● The machine will not start if the number of sets set is the same as the number of sets already processed. In such cases, press the  (Clear) button once, and set “0” for the number of sets already processed.
● If the machine has been stopped by pressing the stop button twice while processing a set, it will start processing that set from the beginning again when restarted.

7. PAPER FEEDER B (COVER FEEDER)

The paper feeder B feeds cover paper. Use only when inserting cover paper. After the number of sheets set has been fed from paper feeder A, only one sheet will be fed from paper feeder B as the cover paper.

7-1. Using the Paper Feeder B

Set as follows when using the paper feeder B to insert the cover paper.

- 1 Turn the jog dial at the initial screen to display “B Sheet Set.” and press the jog dial.

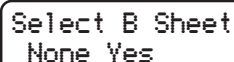

Select B Sheet
None Yes

- 2 To use the paper feeder B, turn the jog dial until “Yes” is displayed at the left edge, and then press the jog dial to confirm the setting.
If not using, turn until “None” is displayed and press the jog dial.

NOTE : The cover paper fed from the paper feeder B is not included in the number of sheets of the set.

8. END MARK DETECTION FUNCTION

This machine comes with an end mark detection function at the paper feeder A. This function detects collation and paper feed errors, and prevents binding errors.

There are two types of end mark detection functions: “Number/set check function” and “Random binding function”.

8-1. Number/Set Check Function (Count) and Random Binding Function (Random) Using the End Mark

- (1) The number/set check function (Count) using the end mark determines that the process is normal and continues the process if the end mark is present on the last page of the number of sheets entered for the set processed. It determines that an error has occurred and stops the machine if the end mark is not on the last page. By checking that the end mark is present on the last page of the set, page deviation is prevented.

NOTE : ● The cover page fed from the paper feeder B is not included in the number of sheets of the set.
● Label the end mark only on the last page of each set fed from the paper feeder A.
● If the end mark is not on the last page of the number of sheets set, “EndMark Error” will be displayed, and the machine will stop.

- (2) The random binding function (Random) determines the page with the end mark as the last page of the set (excluding the cover page) without the number of sheets entered for the set, and performs downstream processing.

This enables continuous binding of sets with different number of sheets.

NOTE : ● When using the random binding function, take note of the restrictions imposed such as printing restrictions of all paper, and the double-feed detection method is fixed to “Sheet”. Refer to “8-3. Printing the End Mark”.
● The recommended paper thickness is 80 g/m² when using the random binding function.
● If the mark is not detected within the number of sheets which can be set at the “Number Of Sheets” screen, “EndMark Error” will be displayed, and the machine will stop.
● When performing saddle-stapling/folding and center-folding operations by connecting the downstream processing unit, each set processed should only differ by within 1 mm (0.04”) in thickness and 5 sheets. If the difference exceeds this, the downstream processing unit will not be able to adjust to each set properly, resulting in paper jam.
● The finish of each set will be poorer, the larger is the difference in the number of sheets of each set.

8-2. Setting the End Mark Detection Function

Select whether to use or not use the end mark detection function, and set the position and processing method of the end mark if using the function.

To use the end mark detection function, turn the jog dial at the initial screen to display “Endmark Set.”, and press the jog dial to confirm the setting.

1 Set the sensor according to the paper face printed with the end mark.

- ① When paper has been placed on the paper feed tray A, turn the jog dial until “Sensor1 Set.” is displayed to detect end marks at the top face, and press the jog dial to confirm the setting. To detect end marks at the bottom face, turn until “Sensor2 Set.” is displayed, and press the jog dial to confirm the setting.
- ② Turn the jog dial and display “Sensor1 on/off” or “Sensor2 on/off”, and press the jog dial to confirm the setting.
- ③ Turn the jog dial and display “On” at the left edge, and press the jog dial to confirm the setting.

NOTE : ● If there are end marks only on the top face, set “Sensor2 Set.” to “Off”. If there are end marks only on the bottom face, set “Sensor1 Set.” to “Off”. If the setting remains at “On”, misdetection may occur.
 ● If “Sensor1 Set.” and “Sensor2 Set.” are both set to “Off”, the end mark detection function will be automatically set to “None”.

2 Select whether to use or not use the end mark detection function.

- ① Turn the jog dial until “Mark Mode” is displayed, and press the jog dial to confirm the setting.

Select Mark Mode
None Count Rand

- ② Turn the jog dial and display “Count” or “Random” at the left edge, and press the jog dial to confirm the setting.
 (If not using the end mark detection function, turn the jog dial to display “None” at the left edge, and press the jog dial.)

NOTE : ● To set the end mark detection function to “Count” or “Random”, either “Sensor1 Set.” or “Sensor2 Set.” must be set to “On”.
 ● When the double-feed detection method is set to “Set”, the end mark detection function cannot be set to “Random”.
 ● When set to “Random”, the count of the number of processed sets will be displayed.

3 Set the end mark position in respect to the paper feed direction.

- ① With the “Sensor1 on/off” or “Sensor2 on/off” displayed (step 1), turn the jog dial, display “Sensor1 Position” to set the end mark position on the top face or “Sensor2 Position” to set the end mark position on the bottom face, and press the jog dial to confirm the setting.
- ② As the number at the bottom will be blinking, turn the jog dial and select the position from the paper tip, and press the jog dial to confirm the position selected.
(Normally, the position will be automatically set to the distance (mm) from the tip of the paper size selected to the center of the paper. When the paper size or downstream processing unit processing mode has been changed or the power supply turned on, be sure to return the setting to the center of the paper. If the mark was set at a position other than the center, be sure to set the mark at that position.)

- NOTE** :
- Set the end mark position after setting the paper size and downstream processing unit processing mode.
 - Only for the automatic size detection function will the previously set mark position be set regardless of the paper size and processing mode. The mark position will be set at the center of the paper for unsettable positions.
 - Do not set in the area measuring 30 mm (1.18") from the tip or end of the paper, and outside the area measuring 300 mm (11.81") from the tip of the paper.
 - Set the end mark position avoiding the double-feed detection area indicated in “13-5. (1) (d) Setting the position for starting the double-feed detection”. Misdetection may occur if the position of the end mark overlaps with the double-feed detection area.

4 Press the ↵ (Escape) button to return to the initial screen.

When the number/set check function using the end mark is selected, “MC” will be displayed at the bottom right of the initial screen. When the random binding function is selected, “MR” will be displayed.

A3
5555/7777(10) MC

8-3. Printing the End Mark

- Set only one end mark for solid printing (black) using a laser printer.
- For marks positioned along the vertical (paper feed) direction, the center is the standard position. But the setting can be changed by entering the desired position using numbers. (Refer to “8-2. Setting the End Mark Detection Function”.)
- Marks positioned along the horizontal direction must be in the area from less than 10 mm (0.39") to more than 20 mm (0.79") from the paper edge of the non-operating side. Printing thickness must be 1.2 to 2.0 mm (0.05" to 0.08").
- Be sure to set a area where nothing else except for the end mark can be printed within 10 mm (0.39") from the center of the end mark in the vertical (paper feed) direction. Also do not print anything in the 2 mm (0.08") area from the paper tip.
- Do not print the end mark in the area measuring 30 mm (1.18") from the tip or end of the paper, and outside the area measuring 300 mm (11.81") from the tip of the paper.
- Do not print the end mark in the double-feed detection area indicated in “13-5. (1) (d) Setting the position for starting the double-feed detection”. Misdetection may occur if the position of the end mark overlaps with the double-feed detection area.

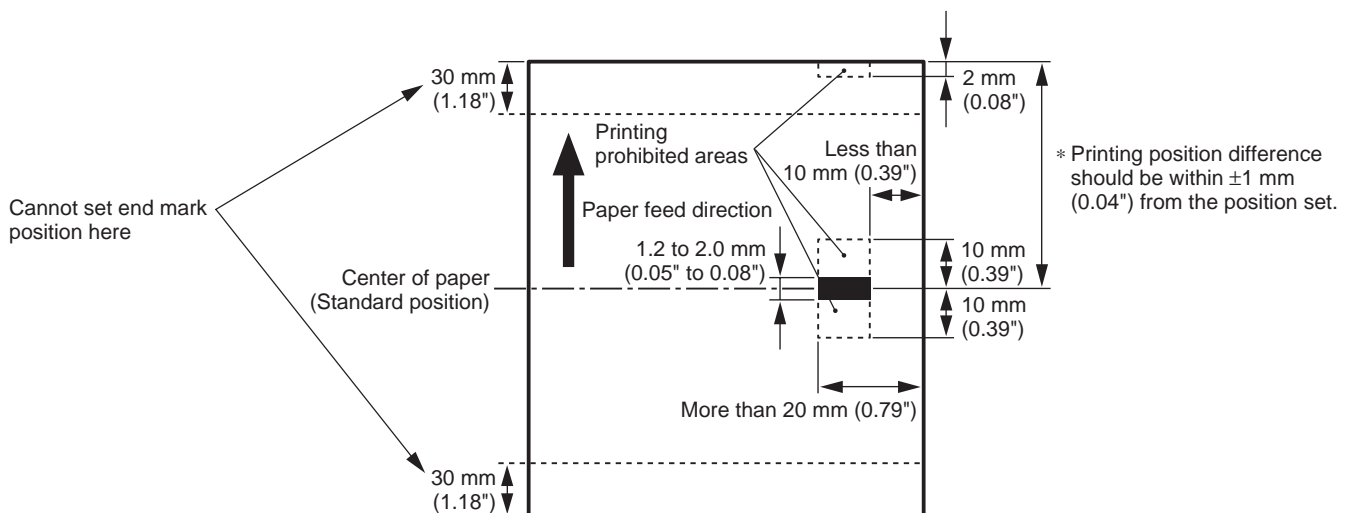

- NOTE :**
- Use white paper for printing end marks. When other types (especially dark paper) are used, the end mark may not be read.
 - When using the random binding function, do not print anything in the above printing prohibited areas on all sheets (pages), and print the end mark only on the last page.
 - Determine the end mark state in the test feeding before continuous operations. If using the number/set check function with the double-feed detection method set to “Sheet” or random binding function, perform test feeding using paper already printed with the end mark. If end mark errors occur frequently during processing, recheck the settings of the end mark and perform test feeding again.

9. REVERSAL MECHANISM

When the reversal mechanism is used, the paper fed using the paper feeder A can be reversed and sent to the downstream processing unit.

9-1. Selecting the Reversal Mechanism

- 1 When using the reversal mechanism, turn the jog dial at the initial screen to display “Inverter Mode” and press the jog dial to confirm the setting.

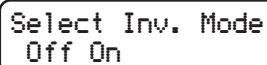

Select Inv. Mode
Off On

- 2 Turn the jog dial and display “On” at the left edge when using the reversal mechanism, and display “Off” if not using the reversal mechanism, and press the jog dial to confirm the setting.

- 3 Press the ↵ (Escape) button to return to the initial screen.
When use of the reversal mechanism is selected, “*” will be displayed at the top right of the initial screen.

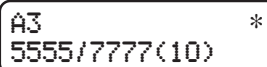

A3 *
5555/7777(10)

10. AUTOMATIC SIZE DETECTION FUNCTION

This machine is equipped with a function which automatically detects the paper size during test feeding without the need to input the paper size when saddle-stapling or center-folding specific standard size paper with the DBM-120 Sheet by Sheet.

This function will not work if “Finisher Mode” is set to “Side ST”, “Corn.ST”, or “Through”.

- NOTE** :
- When the DBM-400 Sheet by Sheet is connected, this function cannot be used.
 - This setting will not change even if the power is turned off and turned on again.

10-1. Detectable Standard Size Paper

The displayed paper size detected differs according to whether it is in mm or inches.

(For details on switching between mm and inches, refer to “13-3. Setting the Millimeters/Inches Display”.)

(1) **Detectable standard sizes for mm display**

A4 (210 × 297 mm), B4 (257 × 364 mm), A3 (297 × 420 mm)

(2) **Detectable standard sizes for inches display**

Letter (8.5" × 11"), Legal (8.5" × 14"), Double Letter (11" × 17")

10-2. Selecting the Automatic Size Detection Function

1 To use the automatic size detection function, turn the jog dial at the initial screen to display “Size Detect Mode”, and press the jog dial to confirm the setting.

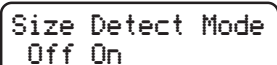

Size Detect Mode
Off On

2 Turn the jog dial and display “On” at the left edge when using the automatic size detection function, and display “Off” if not using the automatic size detection function, and press the jog dial to confirm the setting.

3 Press the ↵ (Escape) button to return to the initial screen.
When the automatic size detection function is used, “ASZ” will be displayed at the top of the initial screen.

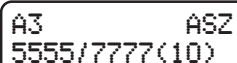

A3 ASZ
5555/7777<10>

- NOTE** : If the paper size could not be detected properly, “No Detect Paper Size” will be displayed. In such cases, set the automatic size detection function to “Off” and set the paper size used manually.
(Refer to “11. SETTING THE PAPER SIZE”.)

11. SETTING THE PAPER SIZE

1 To set the paper size, turn the jog dial at the initial screen to display “Paper Size”, and press the jog dial to confirm the setting.

(The paper size need not be set for saddle-stapling and center-folding if the automatic size detection function has been set by connecting the DBM-120 Sheet by Sheet. The automatic size detection function has priority.)



When the DBM-400 Sheet by Sheet is connected, the paper size will be that registered with the corresponding memory number, according to the paper size set on this unit.

| <Setting paper size of this unit> | | <DBM-400 Sheet by Sheet> |
|-----------------------------------|---|--------------------------|
| A3 | → | Memory number 1 |
| A4 | → | Memory number 2 |
| 11 × 17 | → | Memory number 3 |
| LTR | → | Memory number 4 |
| A3SR | → | Memory number 5 |
| Custom 1 | → | Memory number 6 |
| Custom 2 | → | Memory number 7 |
| Custom 3 | → | Memory number 8 |

NOTE : ● The above are settings for only the vertical feeding of standard size paper (the conveyance direction and longer side of the paper are parallel).

However, if the “Finisher Mode” is set to side-stapling (or corner-stapling) when connecting the DBM-120 Sheet by Sheet, A4 and LTR paper is determined as being conveyed horizontally.

- “Cust1”, “Cust2”, and “Cust3” can be set with any size within the specification. (Refer to “12. CUSTOM SIZES”.)
- When the DBM-400 Sheet by Sheet is connected, “B4” and “LGL” cannot be set.
- If the paper size could not be changed normally due to error of the DBM-400 Sheet by Sheet, the paper size must be changed at the DBM-400 Sheet by Sheet again.

2 Turn the jog dial and display the paper size to be used at the left edge, and press the jog dial to confirm the setting.

3 Press the ↵ (Escape) button to return to the initial screen. The paper size selected will be displayed at the top left of the initial screen.



NOTE : Some paper sizes cannot be set according to the “Finisher Mode” set. Refer to the following table.

When connecting the DBM-120 Sheet by Sheet

| Finisher Mode | Settable Paper Size |
|------------------------|---------------------------|
| Booklet, Fold, Through | All |
| Side ST, Corn.ST | A4, LTR, (Cust1 to Cust3) |

- * If the “Finisher Mode” is set to “Side ST” or “Corn.ST”, A4 and LTR paper will be conveyed horizontally.
- * Custom size can only be set if processable paper sizes are set.
- * For details on processable paper sizes, refer to **the DBM-120 Sheet by Sheet instruction manual**.

When connecting the DBM-400 Sheet by Sheet

| Finisher Mode | Settable Paper Size |
|------------------|--|
| Booklet, Fold | A3, A4, 11 × 17, LTR, A3SR, Cust1 to Cust3 |
| Side ST, Corn.ST | Cust1 to Cust3 |

- * Custom size can only be set if processable paper sizes are set.
- * For details on processable paper sizes, refer to **the DBM-400 Sheet by Sheet instruction manual**.

12. CUSTOM SIZES

This machine is able to set three paper sizes (custom size) within the specification other than standard paper sizes.

12-1. Entering the Custom Size

1 To enter the custom size, turn the jog dial at the initial screen to display “Custom Size”, and press the jog dial to confirm the setting.

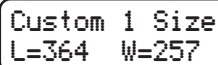

Custom 1 Size
L=364 W=257

2 Turn the jog dial and display the entered custom number (“Custom 1 Size”, “Custom 2 Size”, or “Custom 3 Size”), and press the jog dial to confirm the setting.

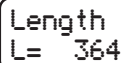

Length
L= 364

3 In this state, turn the jog dial to display “Length” or “Width”, and press the jog dial to confirm the setting.

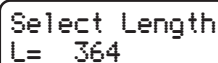

Select Length
L= 364

4 Turn the jog dial and change the value set, and press the jog dial to confirm the setting. To enter both the length and width, enter the desired value for the other setting in the same way. After entering, press the ↵ (Escape) button to return to the initial screen.

- NOTE** :
- “Length” is the conveyed direction of the paper while “Width” is the direction moved by the side guide A.
 - If the size of the same custom number as that displayed on the initial screen has been changed, select this custom number again when setting the paper size.
 - The custom size which can be entered is restricted to within the paper specifications designated by each downstream processing unit, according to the “Finisher Mode” currently set. For details of the range of custom size which can be entered, refer to the respective instruction manuals of the downstream processing units.

13. OTHER SETTINGS

Various settings are available according to purpose of use. After setting, press the ↵ (Escape) button until the initial screen is displayed.

13-1. Setting the Buzzer On/Off

The buzzer which sounds when the jog dial or a button on the control panel is pressed or when an error occurs can be turned off.

- 1 Turn the jog dial at the initial screen to display “Other Setting”, and press the jog dial to confirm the setting.
- 2 Turn the jog dial to display “Tone”, and press the jog dial to confirm the setting.

Tone on/off
On Off

- 3 To sound the buzzer, turn the jog dial until “On” is displayed at the left edge, and press the jog dial to confirm the setting. To turn off the buzzer, turn until “Off” is displayed.

13-2. Setting the Shift Speed and Blink Speed of the LCD

The shift speed (display moving speed) and blink speed (display blinking speed) of the LCD can be each changed in 4 steps.

- 1 Turn the jog dial at the initial screen to display “Other Setting”, and press the jog dial to confirm the setting.
- 2 Turn the jog dial to display “LCD Setting”, and press the jog dial to confirm the setting.

Shift Speed
Normal

- 3 To set the shift speed, turn the jog dial to display “Shift Speed”, and press the jog dial to confirm the setting. To set the blink speed, turn the jog dial to display “Blink Speed”.

Select Shift Sp.
Fast Normal Slo

Select Blink Sp.
Fast Normal Slo

- 4 Turn the jog dial until the desired speed is displayed at the left edge, and press the jog dial to confirm the setting.

13-3. Setting the Millimeters/Inches Display

The custom size entered can be displayed in millimeters or inches.

1 Turn the jog dial at the initial screen to display “Other Setting”, and press the jog dial to confirm the setting.

2 Turn the jog dial to display “mm/In Setting”, and press the jog dial to confirm the setting.

Select mm/In
Meter Inch

3 To display in mm, turn the jog dial until “Meter” is displayed at the left edge, and press the jog dial to confirm the setting. To display in inches, turn until “Inch” is displayed.

NOTE : For “Endmark Set.”, the end mark position entered will be displayed only in mm and not in inches.

13-4. Changing the Set Speed/Paper Feed Speed (Changing the Processing Speed/Paper Feed Interval)

This machine is able to change the time from one paper feed by the paper feeder A to the next paper feed (paper feed speed), and the time from the paper feed of the last paper in the set to the paper feed of the next set (set speed).

NOTE : The set speed is not the number of sets actually processed.

- 1 Turn the jog dial at the initial screen to display “Other Setting”, and press the jog dial to confirm the setting.
- 2 Turn the jog dial to display “Feed Setting”, and press the jog dial to confirm the setting.
- 3 To change the set speed, turn the jog dial to display “Set Speed”, and press the jog dial to confirm the setting. To change the paper feed speed, turn the jog dial to display “Sheet Speed”.

Input Speed
40

- The set speed is not the number of sets actually processed in one minute, but is the number of sets that will be processed in one minute when there is one sheet per set and paper feeder B is not used. The smaller the value, the longer will the interval between the feeding of the last sheet in the set to the feeding of the first sheet in the next set be. Normally, stapling is carried out by the downstream processing unit within this time. (When the reversal mechanism is used without using paper feeder B, time will be added for the reversal operation.) If the operation is still too slow for the next downstream processing unit operation when the DBM-120 Sheet by Sheet is connected, the speed can be changed between 15 to 40 sets/minute (if the paper length exceeds 300 mm (11.81"), 15 to 30 sets/minute). If the DBM-400 Sheet by Sheet is connected, it will be set to the standard setting of 60 sets/minute. Normally, the interval will be automatically adjusted to the operations of the downstream processing unit.
- The initial setting of paper feed speed is the standard speed for each paper size. It is 120 sheets/minute when vertically feeding A4 paper, and 100 sheets/minute when vertically feeding A3 paper. This value is the number of sheets fed when paper is fed continuously for one minute without using the reversal mechanism. It can be set in units of 10 sheets in the range between “40” and “maximum speed of each paper size”. (This value will become slower depending on the paper state.) This speed is fixed when the reversal mechanism is used.

NOTE : When connected with DBM-120 Sheet by Sheet, if paper feed speed is set faster than the standard, any paper jam may occur according to paper quality.

Remark : The paper feed speed when the reversal mechanism is used is as follows. However, it may differ according to the paper state.

A4 (Vertical feed): Approx. 60 sheets/minute

A3 (Vertical feed): Approx. 50 sheets/minute

13-5. Setting the Double-feed Detection Sensor

The double-feed detection sensor compares the characteristics data of the paper test-fed and paper being processed, and determines that double-feeding has occurred when the difference in characteristics is large. The sensor also detects paper jams. The settings of the double-feed detection sensor of the paper feeder need to be changed according to the paper and purpose.

1 Turn the jog dial at the initial screen to display “Other Setting”, and press the jog dial to confirm the setting.

2 Turn the jog dial to display “D-feed Sensor”, and press the jog dial to confirm the setting. Turn the jog dial and select the item from (1) to (3) below to be changed, and press the jog dial to confirm the setting.

(1) Setting the double-feed detection sensor of the paper feeder A

Select to use the double-feed detection function of the paper feeder A, and set the paper thickness, double-feed detection sensitivity, and position to start double-feed detection.

Turn the jog dial to display “A Tray Setting”, and press the jog dial to confirm the setting.

(a) Using the double-feed detection function

Turn the jog dial to display “A Tray Check”, and press the jog dial to confirm the setting.

Turn the jog dial and display “On” at the left edge when using the double-feed detection function, and display “Off” if not using the function, and press the jog dial to confirm the setting.

Check on/off
Off On

NOTE : When set to “Off”, the machine will not stop even when double-feeding occurs.

(b) Setting the thickness of the paper

Turn the jog dial to display “A Tray Thick”, and press the jog dial to confirm the setting.

Turn the jog dial and display “Auto”, “Heavy”, or “Thin” at the left edge according to the paper used, and press the jog dial to confirm the setting.

Select Thick
Auto Heavy Thin

Approximate settings (Paper feeder A)

| Setting | Condition (Approximation) |
|---------|--|
| Auto | When paper thickness is 52 to 128 g/m ² (standard) |
| Heavy | If misdetection occurs when set to “Auto” in the use of colored paper |
| Thin | If misdetection occurs when the paper thickness is less than 70 g/m ² and set to “Auto” |

NOTE : ● Even when the double-feed detection function is set to “Off”, be sure to change the setting according to the paper used.

● If this setting is not appropriate, double-feeding will not be detected properly, and in addition the paper feed error of the paper forwarding just a little and then stopping will occur frequently.

● If settings have been changed, be sure to perform test feeding.

(c) Setting the sensitivity of the double-feed detection

Turn the jog dial to display “A Tray Level”, and press the jog dial to confirm the setting.

Turn the jog dial and display the desired sensitivity at the left edge, and press the jog dial to confirm the setting.

The sensitivity can be selected from five levels “17, 20, 25, 33, and 50”.

Select Level
17 20 25 33 50

Remark : ● To detect double-feeding, the state of the paper test-fed (light transparent amount) is memorized, and the paper fed is compared with this value with each sheet.

When the sensitivity is set at “17”, double-feeding is determined when the difference is above 17%.

● For “17”, double-feeding will be detected at the slightest difference. The closer the level to “50”, the less will double-feeding be detected according to the difference.

13. OTHER SETTINGS

(d) Setting the position for starting the double-feed detection

Turn the jog dial to display “A Tray Position”, and press the jog dial to confirm the setting.

Turn the jog dial and display the desired detection start position at the left edge, and press the jog dial to confirm the setting.

Select Position
120 130 140 150

NOTE : If settings have been changed, be sure to perform test feeding.

The standard double-feed detection start position is on the 11 mm (0.43") line from the edge of the reference side of the paper (non-operating side), detection starts from the 120 mm (4.72") point from the tip of the direction in which paper advances and continues for an area of about 35 mm (1.38") (about 155 mm (6.10") from the tip) from this point. If there is printing in this area, double-feed detection may not be performed properly. In this case, the detection start position can be selected in units of 10 mm (0.39") within the range of 120 to 170 mm (4.72" to 6.69") from the tip of the paper. Set avoiding printed area.

NOTE : Set the double-feed detection start position so that the end mark does not enter the double-feed detection area.

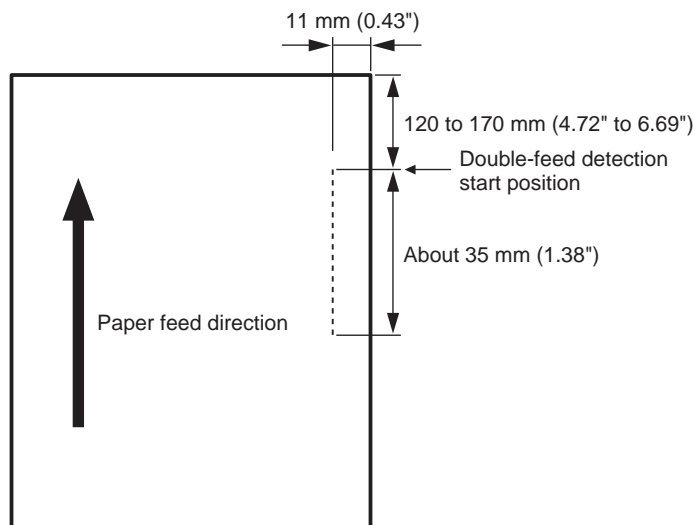

(2) Setting the double-feed detection sensor of the paper feeder B

Select to use the double-feed detection function of the paper feeder B, and set the paper thickness, double-feed detection sensitivity, and position to start double-feed detection.

Turn the jog dial to display “B Tray Setting”, and press the jog dial to confirm the setting.

(a) Using the double-feed detection function

Turn the jog dial to display “B Tray Check”, and press the jog dial to confirm the setting.

Perform the same operation as when using the double-feed detection of paper feeder A.

(Refer to (a) in (1) on the before section.)

(b) Setting the thickness of the paper

Turn the jog dial to display “B Tray Thick”, and press the jog dial to confirm the setting.

Perform the same operation as when setting the paper thickness of paper feeder A.

(Refer to (b) in (1) on the before section.)

Select Thick
Auto Heavy Thin

Approximate settings (Paper feeder B)

| Setting | Condition (Approximation) |
|---------|--|
| Auto | When paper thickness is 52 to 250 g/m ² (standard) |
| Heavy | If misdetection occurs when set to “Auto” for dark prints |
| Thin | If misdetection occurs when the paper thickness is less than 70 g/m ² and set to “Auto” |

NOTE : ● Even when the double-feed detection function is set to “Off”, be sure to change the setting according to the paper used.

● If this setting is not appropriate, double-feeding will not be detected properly, and in addition the paper feed error of the paper forwarding just a little and then stopping will occur frequently.

● If settings have been changed, be sure to perform test feeding.

(c) Setting the sensitivity of the double-feed detection

Turn the jog dial to display “B Tray Level”, and press the jog dial to confirm the setting.

Perform the same operation as when setting the double-feed detection sensitivity of paper feeder A.

(Refer to (c) in (1) on the before section.)

(d) Setting the position for starting the double-feed detection

Turn the jog dial to display “B Tray Position”, and press the jog dial to confirm the setting.

Perform the same operation as when setting the double-feed detection start position of paper feeder A.

(Refer to (d) in (1) on the before section.)

(3) Setting the double-feed detection method

There are two methods of double-feed detection: “Set” and “Sheet”.

Turn the jog dial to display “Check Mode” at the top, and press the jog dial to confirm the setting.

To set “Set”, turn the jog dial and display “Set” at the left edge, or to set “Sheet”, turn the jog dial and display “Sheet” at the left edge, and press the jog dial to confirm the setting.

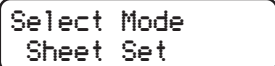

```
Select Mode
Sheet Set
```

NOTE : If the end mark detection function is set to “Random” or the downstream processing unit is set to “Through”, “Set” cannot be set.

“Set” method

With “Set”, all sheets in one set will be test fed, the characteristics of all these sheets and each sheet actually processed will be compared to determine double-feeding. When this method is selected, double-feeding can be detected even if different color paper is included in the set.

“Sheet” method

With “Sheet”, only the first sheet in each paper feeder will be test fed, and the characteristics of this sheet and all the sheets actually processed will be compared to determine double-feeding. When using this method, use only the same color paper. Also do not print anything in the double-feed detection area. (However this not apply when all sheets have the same printing at the same area.)

13-6. Selecting the Separator Air Strength

The separator air strength can be selected from three steps. If paper feed errors occur frequently at standard value “1”, change the setting and set the most appropriate value. If the paper is large and thick, set the air strength to high. If the paper is small and thin, set the air strength to low.

1 Turn the jog dial at the initial screen to display “Other Setting”, and press the jog dial to confirm the setting.

2 Turn the jog dial to display “Blower Strength”, and press the jog dial to confirm the setting.

Blower Stre. A
1

3 To change the separator air strength of the paper feeder A, turn the jog dial to display “Blower Stre. A”, and press the jog dial to confirm the setting. To change that of the paper feeder B, display “Blower Stre. B”, and press the jog dial to confirm the setting.

Select Stre. A
1 2 3

4 Turn the jog dial and display the desired value at the left edge, and press the jog dial to confirm the setting.

- “1” is the maximum air amount and “3” is the smallest. The standard value is “1”.

13-7. Setting the Driving Time of Suction Belt

The driving time of the suction belt (paper feed clutch connecting time) can be set. If paper feed errors occur frequently at standard value "2", change the setting. When feeding long paper such as A3 paper, set a long suction belt driving time. If below 300 mm (11.81"), set a short suction belt driving time.

1 Turn the jog dial at the initial screen to display "Other Setting", and press the jog dial to confirm the setting.

2 Turn the jog dial to display "Feed Cl. Timing", and press the jog dial to confirm the setting.

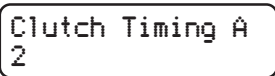

Clutch Timing A
2

3 To change the suction belt driving time of the paper feeder A, turn the jog dial to display "Clutch Timing A", and press the jog dial to confirm the setting. To change that of the paper feeder B, display "Clutch Timing B", and press the jog dial to confirm the setting.

4 Turn the jog dial to display the desired value at the left edge, and press the jog dial to confirm the setting. The values can be changed in 6 steps from "1 to 6".

- "1" is the shortest driving time and "6" is the longest. The standard value is "2".

13-8. Setting the Subtraction Processing and Addition Processing

Select whether to display the number of processed sets or number of remaining sets at the initial screen of the LCD.

1 Turn the jog dial at the initial screen to display "Other Setting", and press the jog dial to confirm the setting.

2 Turn the jog dial to display "No. Of Sets", and press the jog dial to confirm the setting.

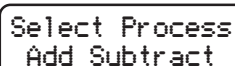

Select Process
Add Subtract

3 To display the number of processed sets at the initial screen of the LCD, turn the jog dial to display "Add" at the left edge, and press the jog dial to confirm the setting. To display the number of remaining sets, display "Subtract" at the left edge, and press the jog dial to confirm the setting.

13-9. Setting of No. of Jogged Sheets

The timing for side jogging by the downstream processing unit (side jogging should be performed after how many sheets it has received from this machine) can be changed within the range of 1 to 5 sheets.

With the default setting, side jogging is performed after every 5 sheets. However if paper is not aligned properly, set to a smaller number.

1 Turn the jog dial at the initial screen to display “Other Setting”, and press the jog dial to confirm the setting.

2 Turn the jog dial to display “Sheet Jog”, and press the jog dial to confirm the setting.

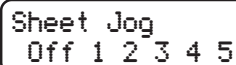

Sheet Jog
Off 1 2 3 4 5

3 Turn the jog dial to display the desired number of sheets at the left edge, and press the jog dial to confirm the setting.

Remark : Side jogging will not be performed while a set is being processed when set to “Off”.

NOTE : When the DBM-400 Sheet by Sheet is connected, it is necessary to set in the DBM-400 Sheet by Sheet side whether to use this function. If this unit is set to “Off”, set the DBM-400 Sheet by Sheet also to “OFF”. If setting this unit to “1” to “5” and using this function, set the DBM-400 Sheet by Sheet to “ON”.

Setting the DBM-400 Sheet by Sheet

① Press the “Function” key and then “9” key. The following will be displayed on the LCD.



9•Mode Select 2

② Press the “Set” key and then “4” key. The following will be displayed on the LCD.



4•Jog-Asst OFF

③ While pressing the “Change” key, press “4” key to switch between ON and OFF.

14. PAGE ORDER AND DIRECTION OF PAPER ON THE PAPER FEED TRAY

14-1. Paper Stacked on Paper Feed Tray A

- (1) **When saddle-stapling/folding or center-folding paper in the downstream processing unit**
Stack paper which has been collated in order on the paper feed tray A. Stack the paper in the order and direction shown in the figure.

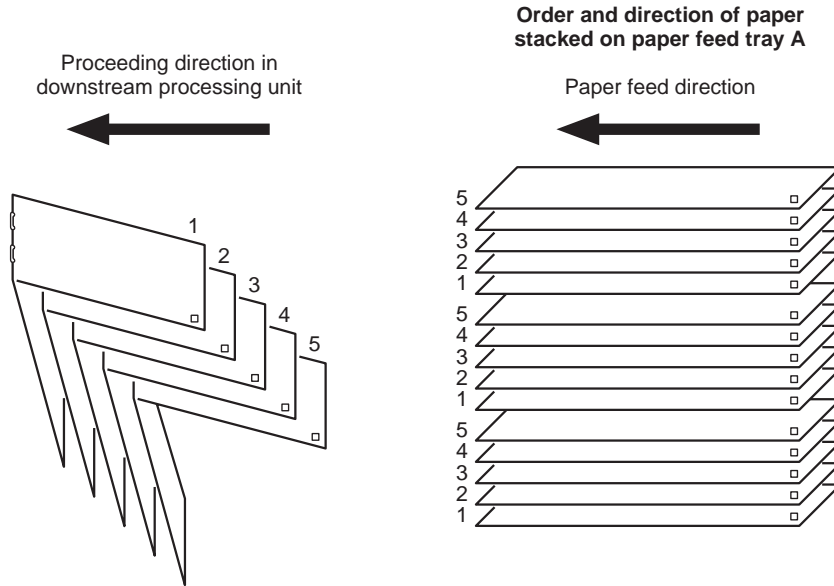

- (2) **When side-stapling or corner-stapling in the downstream processing unit**

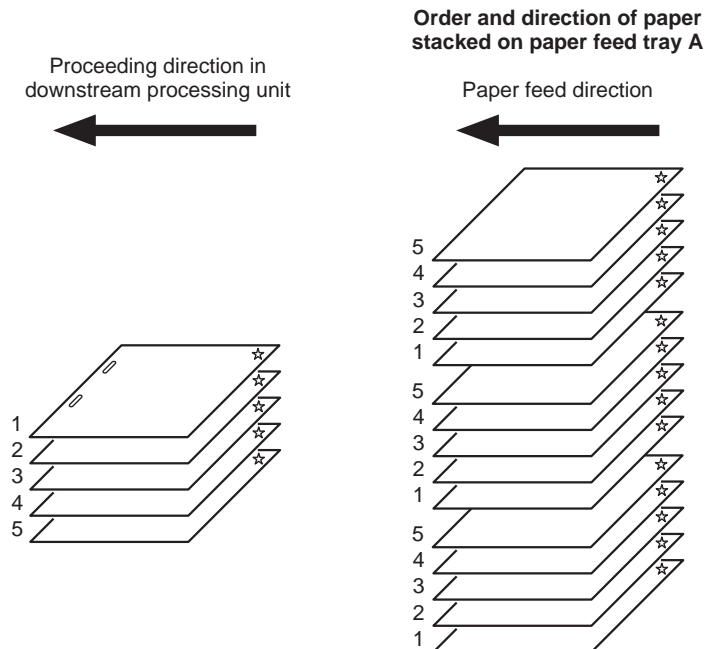

14. PAGE ORDER AND DIRECTION OF PAPER ON THE PAPER FEED TRAY

- (3) When saddle-stapling/folding or center-folding in the downstream processing unit using a reversal mechanism

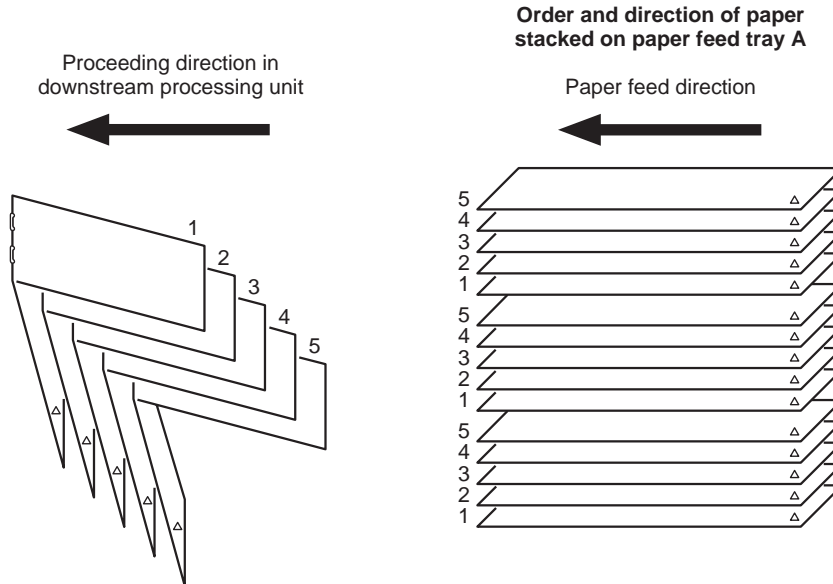

- (4) When side-stapling or corner-stapling in the downstream processing unit using a reversal mechanism

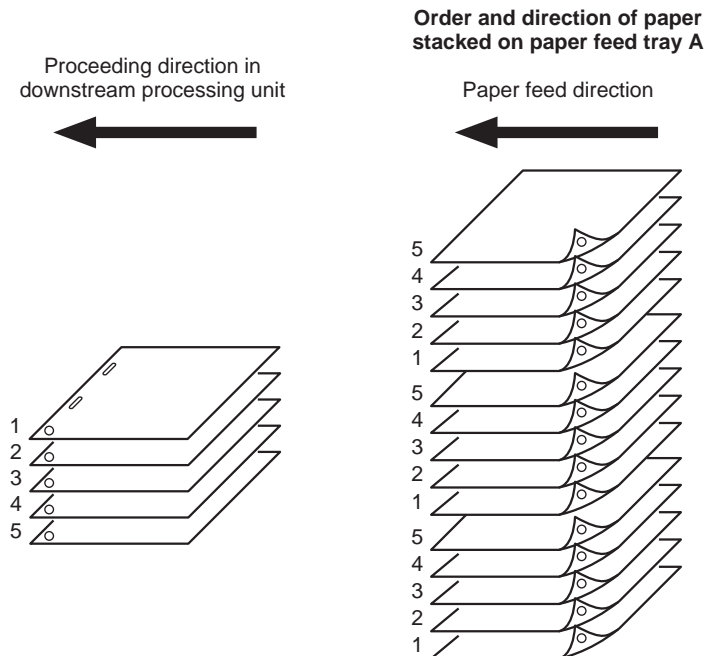

14-2. Paper Stacked on Paper Feed Tray B

(1) When saddle-stapling/folding or center-folding in the downstream processing unit

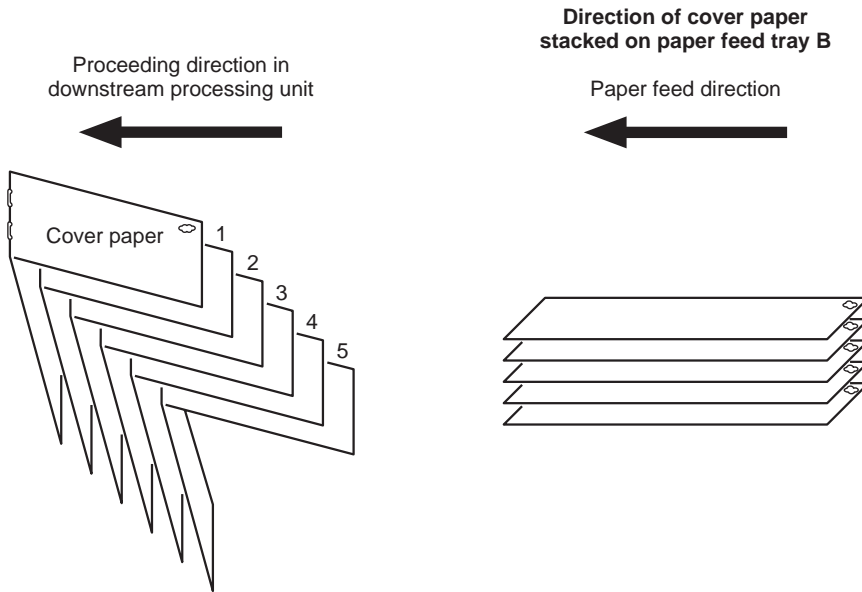

(2) When side-stapling or corner-stapling in the downstream processing unit

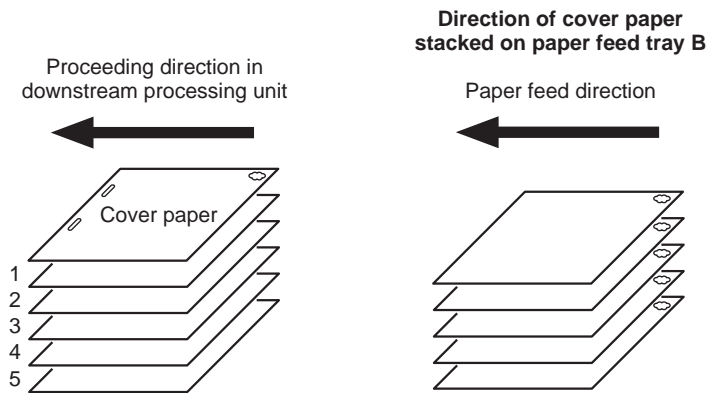

15. STACKING PAPER ON THE PAPER FEEDER A AND ADJUSTING PAPER FEED

1 Move the auxiliary paper feed plate A to the appropriate position.

- Push and slide the center part of the auxiliary paper feed plate A to the left and right.

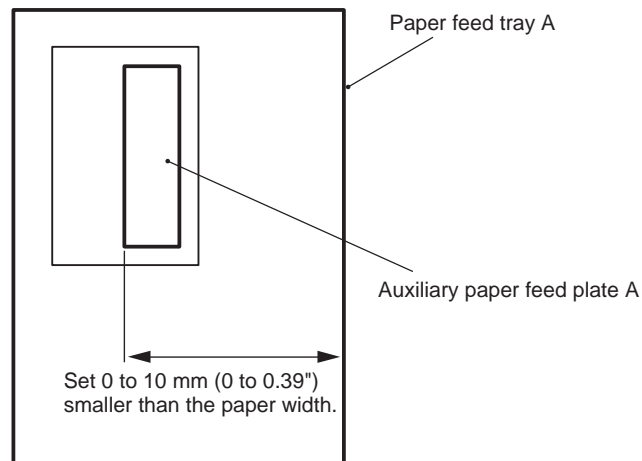

- If the paper width is less than 200 mm (7.87"), remove the auxiliary paper feed plate A. Lift up to remove the auxiliary paper feed plate A. To reattach, insert into the slit of the paper feed tray A in the direction shown in the figure.

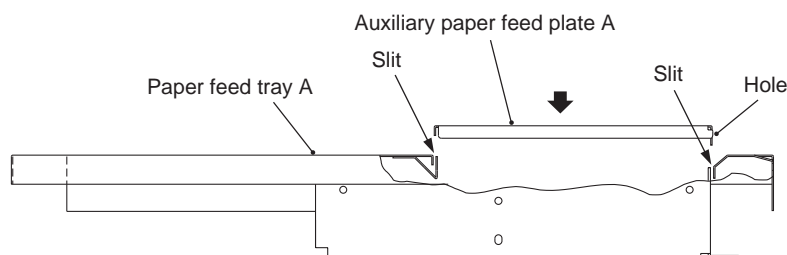

2 Stack paper on the paper feed tray A.

- Raise the rear guide A until it touches the magnet before stacking the paper. Arrange the tip and side of the paper properly, and stack it gently pressing against two guides so that there is no gap between the tip and right side (level sensor side) of the paper and each guide.

After stacking the paper, lower the rear guide A, and move to a position in front of the rear of the paper.

- For details on the order and direction of the paper stacked, refer to "14-1. Paper Stacked on Paper Feed Tray A".

- NOTE** :
- Separate the paper properly before stacking. Otherwise, problems such as double-feeding may occur.
 - Flatten curled paper or bent paper before stacking. Otherwise, problems such as paper jamming may occur.
 - Do not mix paper of different sizes and paper quality.

3 Move the side guide A until it touches the paper.

- Turn the side guide moving dial A until the side guide A touches the left side of the paper.

- NOTE** : If mis-feeding frequently occurs with paper above 100 g/m², leave a space of 0.5 mm (0.02") between the paper and side guide A.

15. STACKING PAPER ON THE PAPER FEEDER A AND ADJUSTING PAPER FEED

4 Set the rear guide A at the rear of the paper stacked.

- If the stacked paper is lower than the rear guide such as when only a small amount of paper is stacked, raise the paper feed tray A. (Refer to “5-2. Up/Down Operations of Paper Feed Tray”.)

The rear guide A need not be set at this point, but can be set just before the paper feed tray is raised and the separator air is blown out during test feeding.

5 Adjust the height of the level sensor A.

- The standard position of the level sensor A is as shown in the figure.
- Moving the level sensor A knob to the lower arrow side raises the paper feed position. Moving to the upper arrow side lowers the paper feed position.
- If mis-feeding occurs easily with thick paper, adjust to the lower arrow side. If double-feeding occurs easily with thin paper, adjust to the upper arrow side.

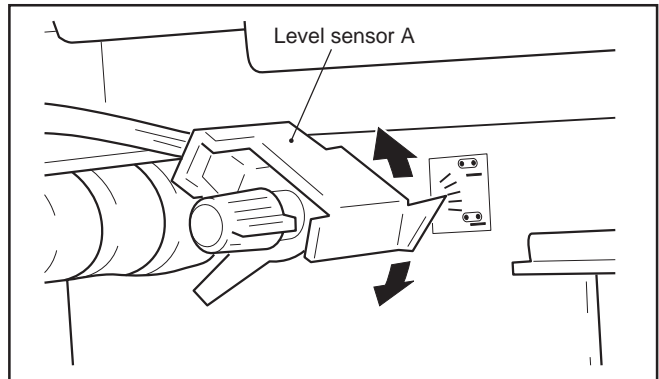

6 Adjust the amount of separator air to separate the paper using the separator air adjustment knob A.

- The larger the number, the greater and more powerful will the separator air blown out be.
- The standard position of the separator air is “2”.
- When using large art paper or coated paper, adjust the separator air adjustment knob to a large setting. When using thin small paper, adjust the separator air adjustment knob to a small setting.

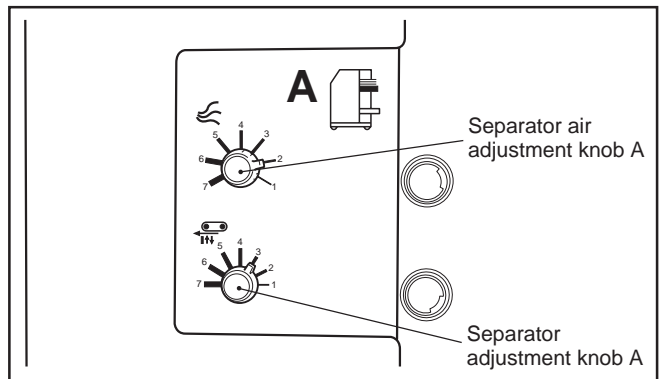

7 Adjust the height of the separator A using the separator adjustment knob A.

- The larger the number, the wider will the gap between the separator A and suction belt be. And the smaller the number, the small will the gap be.
- The standard position of the separator A is “3”.
- If mis-feeding occurs easily when actually feeding paper, adjust the separator adjustment knob to a large setting. If double-feeding occurs easily, adjust to a small setting.

16. STACKING PAPER ON THE PAPER FEEDER B AND ADJUSTING PAPER FEED

1 Stack cover paper on the paper feed tray B.

- Arrange the tip and side of the cover paper properly, and stack it gently pressing against two guides so that there is no gap between the tip and right side (level sensor side) of the paper and each guide.

2 Adjust the level sensor B, B side separator air amount, and separator B in the same way as the paper feeder A. (Adjust with the level sensor B knob, separator air adjustment knob B, and separator adjustment knob B.)

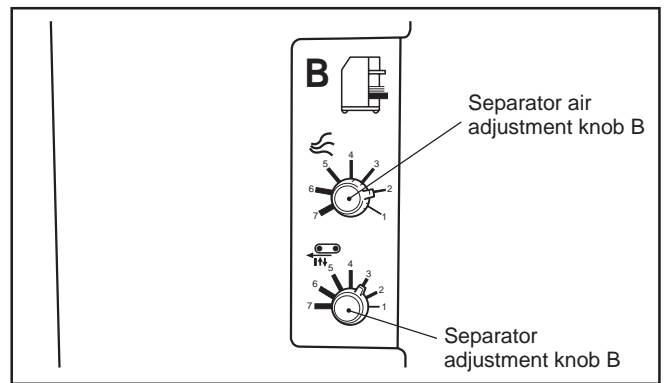
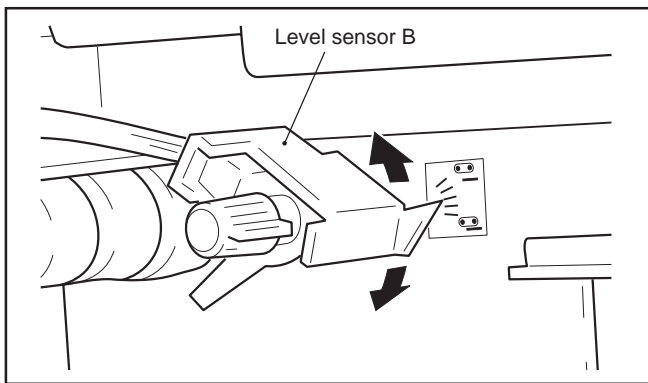

3 Set the stack guide B so that it presses gently against the rear and left side (control panel side) of the cover paper.

- NOTE :**
- Do not set the stack guide B below the suction belt. The stack guide will lift up the suction belt and cause the machine to stop.
 - When the paper is thick (above 127 g/m²) and less than 180 mm (7.09") wide, leave a gap of about 1 mm (0.04") between the left side stack guide and paper.
 - If paper is fed crookedly during the horizontal feeding of A4 paper, set two stack guides B at the rear of the paper. (Three stack guides B are provided as standard accessory.)
 - Pressing the stack guides strongly may cause mis-feeding.
 - Do not mix paper of different sizes and paper quality.

17. AUXILIARY STACK GUIDE A

Use the auxiliary stack guide A if paper is fed crookedly.

Place it on the paper feed tray A so that it presses the sponge at the position where the left side of the paper stacked or the rear end of the paper becomes crooked.

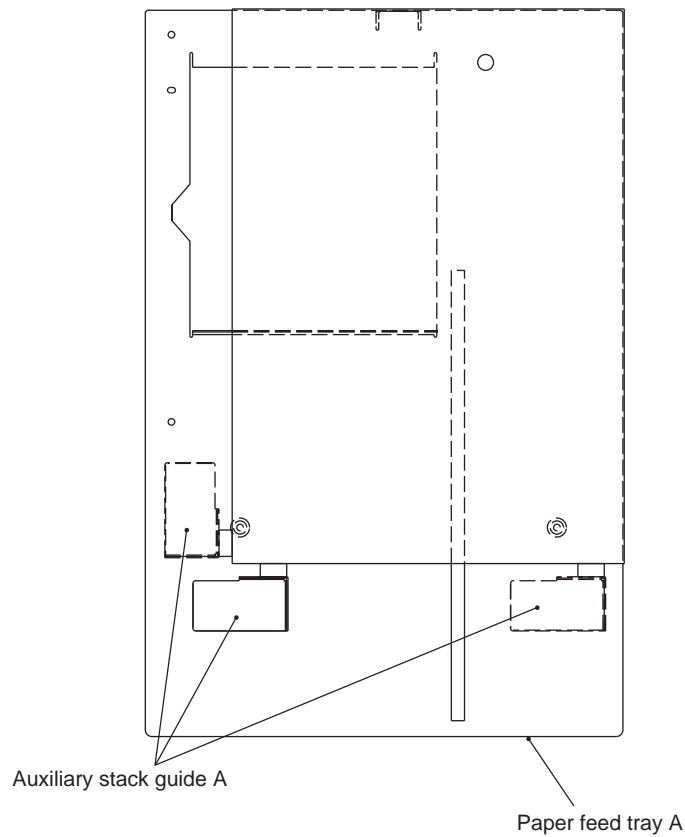

18. WHEN ERROR OCCURS

18-1. Correcting Paper Jamming

When paper jamming occurs, open the upper door, lower door, and bridge door and remove the paper completely before resuming operation. If all of the doors are not opened and closed, the paper-jam error message will not go off even if the jammed paper has been removed and operations cannot be resumed. By opening and closing these doors, the machine will be initialized.

Opening and closing the lower door

To open the lower door, pull up the lower door release lever. To close, slowly push the part indicated “PUSH” on the lower door and close the door.

18-2. When the Error Message “PAPER JAM” is Displayed at the LCD

When paper jamming occurs, “PAPER JAM” will be displayed in the first line of the LCD of the control panel, and the area of the jam will be displayed in the second line.

- “Feed” : Entrance of the paper feed section
- “Conveyance” : Between the entrance of the paper feed section and paper ejection section
- “Eject” : Paper ejection section
- “Turn” : Reversal section
- “DBM-120” : Inside the DBM-120 Sheet by Sheet (Stapler folder)
- “DBM-120T” : Inside the DBM-120T (Trimmer)

At this time, turning the jog dial displays the jam code.

Jam codes

Codes for locating further details of the paper jam which occurred.

- “J1” : Paper jammed or double-feeding occurred at the double-feed sensor of the paper feeder A
(Check the entrance of the paper feeder A and the inside of the upper door.)
- “J2” : Paper jammed or double-feeding occurred at the double-feed sensor of the paper feeder B
(Check the entrance of the paper feeder B and the inside of the lower door.)
- “J3” : Paper jammed between the paper feeder A and paper ejection switch
(Check the inside of the upper door and the bridge door.)
- “J4” : Paper jammed between the paper feeder B and paper ejection switch
(Check the inside of the lower door and the bridge door.)
- “J5” : Paper remaining at the paper ejection switch
(Check the inside of the bridge door and the entrance of the downstream processing unit.)
- “J6” : Paper jammed between the paper feeder A and reversal sensor during reversal
(Check the inside of the upper door.)
- “J7” : Paper remaining at the reversal sensor (from entrance to exit)
(Check the inside of the upper door and the lower door.)
- “J8” : Paper remaining at the reversal sensor (from exit to, re-entrance, to exit)
(Check the inside of the lower door and the bridge door.)
- “F1-Jam” : Inside the DBM-120 Sheet by Sheet
- “F2-Jam” : Inside the DBM-120T

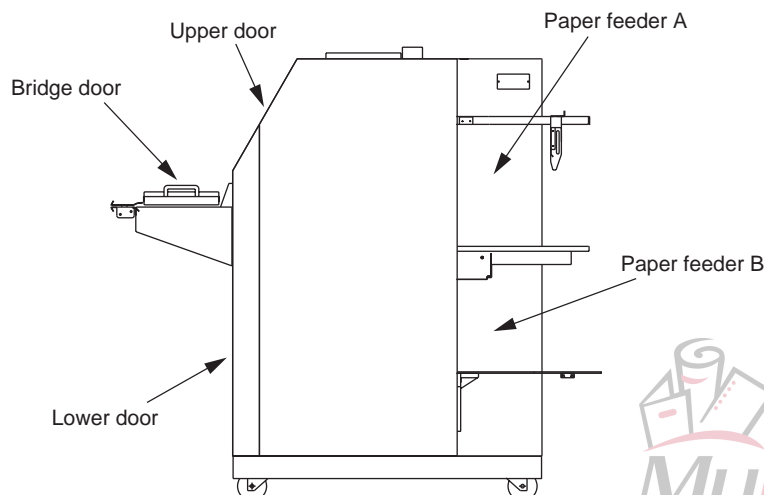

18-3. When the Machine Stops Due to Errors

If this unit stops due to error while operating, restart this unit using the following methods.

(1) To resume operations from where the machine stopped, perform the following operations according to the cause of the error.

- If the machine stopped due to no paper on the paper feed tray, replenish paper and press the start button with “Paper empty” displayed.
- If the machine stopped due to mis-feeding, rearrange the paper at the top of the stack on the paper feeder neatly, and press the start button with “Feed miss” displayed.
- If the machine stopped due to double-feeding, remove the paper in the machine, arrange the paper in the same order as before the paper was fed, place back the paper to the paper feed tray, and press the start button.
- If the machine stopped due to paper jamming, open the door, remove the paper in the machine. “Continue ?” will be displayed. Remove all of paper (including the jammed paper) fed after the paper properly received by the downstream processing unit (paper sent to the standby area before stapling in the downstream processing unit), arrange the paper in the same order as before the paper was fed, place back the paper to the paper feed tray, and press the start button. When paper jamming occurs in the downstream processing unit, refer to **the instruction manual on the downstream processing unit**.

(2) To resume operations after returning all sheets in the error set to the paper feed tray, perform the following operations.

Pressing the stop button when an error other than the above paper jamming and “Continue ?” is displayed (returns to the initial screen) will return the machine to the state before the first sheet of the set was fed even if some sheets in the set had been already fed. At this time, if there are paper remaining in the downstream processing unit, the paper-jam error message will be displayed.

Remove all the paper in the machine (including those in the downstream processing unit), arrange the paper in the same order as before the paper was fed, place back the paper to the paper feed tray, or remove all paper of the set remaining on the paper feed tray, and then press the start button.

18-4. When the Error Message “Finisher Error” is Displayed at the LCD

When error occurs in the downstream processing unit, “Finisher Error” will be displayed in the first line of the LCD of the control panel of this unit, and the error details will be displayed in the second line. For details of errors, refer to **the respective instruction manuals of the downstream processing units** according to the message displayed on the control panel of the downstream processing unit.

- “DBM120 Error” : DBM-120 Sheet by Sheet moderate equipment error
- “DBM120 Trouble” : DBM-120 Sheet by Sheet serious equipment error
- “DBM120T Error” : DBM-120T moderate equipment error
- “DBM120T Trouble” : DBM-120T serious equipment error
- “DBM400 Jam” : Paper jammed in the DBM-400 Sheet by Sheet
- “DBM400 Cover” : Top cover of the DBM-400 Sheet by Sheet is open
- “DBM400 Error” : DBM-400 Sheet by Sheet moderate equipment error
- “DBM400 Trouble” : DBM-400 Sheet by Sheet serious equipment error
- “DBM400 Roller” : Auxiliary roller stay was attached when changing the paper size of the DBM-400 Sheet by Sheet
- “DBM400T Error” : Error occurred in the DBM-400T (downstream processing unit of the DBM-400 Sheet by Sheet)

19. WHEN THE ERROR MESSAGE “Malfunction” IS DISPLAYED

When “Malfunction” is displayed in the first line of the LCD, perform the following procedure.

- Remove any paper in the machine.
- Open and close the upper door, lower door, or bridge door.
- Turn off and then on the power.

If the error message does not go off even after performing the above, contact your dealer. Please let the service personnel have the following information:

- Your name (or the name of the company and person in charge), address, and telephone number
- The model name: DSF-2000 (Sheet feeder)
- Product number
- The message displayed in the second line of the display

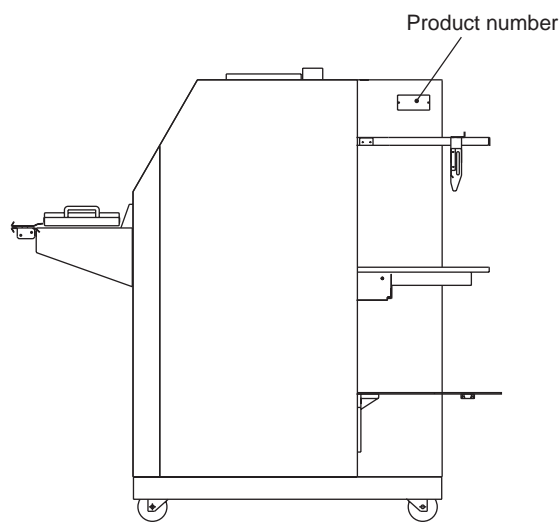

20. CLEANING

- Once a day, clean the conveyance roller and suction belt for conveying paper.
Problems may occur if the conveyance roller and suction belt are dirty.
- Clean by wiping the dirty areas with a cloth moistened with water or alcohol.
- To perform operations after cleaning, do so after making sure the cleaned areas have dried completely.

21. TROUBLESHOOTING

| Symptom | Cause | Remedy |
|---|---|---|
| Double-feeding occurs frequently. | <ul style="list-style-type: none"> ● Improper adjustment of paper feeder. ● Paper is curled up. | <ul style="list-style-type: none"> ● Adjust the level sensor, separator air, and separator of each paper feeder. (Refer to “15. STACKING PAPER ON THE PAPER FEEDER A AND ADJUSTING PAPER FEED” and “16. STACKING PAPER ON THE PAPER FEEDER B AND ADJUSTING PAPER FEED”.) ● Flatten curled paper. |
| Misdetection of double-feed | <ul style="list-style-type: none"> ● Double-feed detection sensor setting is inappropriate. ● The printing position of the end mark is overlapping with the double-feed detection area. | <ul style="list-style-type: none"> ● Set the paper thickness, detection range, and detection method appropriately. (Refer to “13-5. Setting the Double-feed Detection Sensor”.) ● Change the end mark position or the setting of double-feed detection start position. (Refer to “8-2. Setting the End Mark Detection Function” and “13-5. Setting the Double-feed Detection Sensor”.) |
| Mis-feeding occurs frequently. | <ul style="list-style-type: none"> ● Improper adjustment of paper feeder. ● Test feeding was not performed. ● Double-feed detection sensor setting is inappropriate. | <ul style="list-style-type: none"> ● Adjust the level sensor and separator of each paper feeder. (Refer to “15. STACKING PAPER ON THE PAPER FEEDER A AND ADJUSTING PAPER FEED” and “16. STACKING PAPER ON THE PAPER FEEDER B AND ADJUSTING PAPER FEED”.) ● Refer to step 6 in “6. OPERATIONS”. ● Set the paper thickness and detection range appropriately. (Refer to “13-5. Setting the Double-feed Detection Sensor”.) |
| Paper jam detected immediately after paper feed | Double-feed detection sensor setting is inappropriate. | Set the paper thickness and detection range appropriately. (Refer to “ 13-5. Setting the Double-feed Detection Sensor ”.) |
| Power does not turn ON. | Remote switch is set to bottom position. | Set the remote switch position to the top. |
| End mark is not read normally. | <ul style="list-style-type: none"> ● End mark setting is inappropriate. ● End mark is too thin. ● Paper is fed crookedly. | <ul style="list-style-type: none"> ● Set whether to use the end mark, paper face, and position appropriately. (Refer to “8-2. Setting the End Mark Detection Function”.) ● Enter an end mark in solid printing using a laser printer. ● Prevent paper from being fed crookedly using the auxiliary stack guide A. (Refer to “17. AUXILIARY STACK GUIDE A”.) |
| Order of sheets becomes irregular. | <ul style="list-style-type: none"> ● Too much separator air A blown out. ● Position of rear guide is inappropriate. ● Paper not stacked properly. | <ul style="list-style-type: none"> ● Adjust the separator air adjustment knob A to a smaller value. ● Adjust the rear guide to the rear end of the paper. ● Stack the paper neatly. |
| Cannot start. | Number of processed sets is the same as number set, or number of remaining sets is 0. | Press the clear button, and reset the number of processed sets or number of remaining sets. |

22. SPECIFICATIONS

| Model | DSF-2000 |
|-------------------------------------|---|
| Type | Tower floor-type paper feeder (with cover feeder) |
| Feeding system | Belt suction system |
| Maximum paper loading volume | Paper feeder A: 200 mm (7.87") Paper feeder B: 60 mm (2.36") |
| Paper size | Width : 148 to 320 mm (5.83" to 12.60") Length: 200 to 450 mm (7.87" to 17.72") |
| Paper quality | Paper feeder A Fine quality paper : 52 to 128 g/m ² Art/coated paper : 79 to 128 g/m ² Paper feeder B Fine quality paper : 52 to 250 g/m ² Art/coated paper : 79 to 157 g/m ² |
| Paper type | Leaf |
| Processing speed | Maximum 150 sheets/minute (A4 vertical) * But it depends on the specifications of the downstream processing unit if it is used. |
| Feed error detection | Double-feed detection, mis-feed detection, paper jamming detection (paper feed section) |
| Other detection functions | Paper jamming detection (conveyance route), no-paper detection, upper door open/close detection, lower door open/close detection, bridge door open/close detection, end mark error detection |
| Additional function | Reversal function (paper feeder A only) |
| Dimensions | DSF-2000: W × D × H = 1100 × 750 × 1015 mm (43.31" × 29.53" × 39.96") DSF-2000 + DBM-120 Sheet by Sheet + DBM-120T + Stacker: W × D × H = 2750 × 750 × 1015 mm (108.27" × 29.53" × 39.96") DSF-2000 + DBM-400 Sheet by Sheet + DBM-400T + DBM-400LS: W × D × H = 4500 × 750 × 1015 mm (177.17" × 29.53" × 39.96") |
| Power supply | 220 to 240 V AC 50/60 Hz 120 V AC 60 Hz |
| Current consumption | 0.9 A (220 to 240 V AC)/1.8 A (120 V AC) |
| Mass (Weight) | 136 kg (299.56 lb) |

Specifications and dimensions are subject to change without prior notice for improvements.

This manual is printed on recycled paper to help protect the environment.

